

# CIGWELD

AN ESAB BRAND



100+  
YEARS OF  
WELDING  
INNOVATION

# BLUE VENOM



XF195  
XF200<sup>6</sup>  
XF230<sup>6</sup>

POWERED BY



TECHNOLOGY

OPERATING MANUAL

# CIGWELD

AN ESAB BRAND

## WE APPRECIATE YOUR BUSINESS!

Congratulations on your new CIGWELD product. We are proud to have you as our customer and will strive to provide you with the best service and reliability in the industry. This product is backed by our extensive warranty and world-wide service network.

This Operating Manual has been designed to instruct you on the correct use and operation of your CIGWELD product. Your satisfaction with this product and its safe operation is our ultimate concern. Therefore please take the time to read the entire manual, especially the Safety Precautions. They will help you to avoid potential hazards that may exist when working with this product.

We have made every effort to provide you with accurate instructions, drawings, and photographs of the product(s) while writing this manual. However errors do occur and we apologise if there are any contained in this manual.

Due to our constant effort to bring you the best products, we may make an improvement that does not get reflected in the manual. If you are ever in doubt about what you see or read in this manual with the product you received, then check for a newer version of the manual on our website or contact our customer support for assistance.

## YOU ARE IN GOOD COMPANY!

### The Brand of Choice for Contractors and Fabricators Worldwide.

CIGWELD is a Market Leading Brand of Arc Welding Products for ESAB. We are a mainline supplier to major welding industry sectors in the Asia Pacific and emerging global markets including; Manufacturing, Construction, Mining, Automotive, Engineering, Rural and DIY.

We distinguish ourselves from our competition through market-leading, dependable products that have stood the test of time. We pride ourselves on technical innovation, competitive prices, excellent delivery, superior customer service and technical support, together with excellence in sales and marketing expertise.

Above all, we are committed to develop technologically advanced products to achieve a safer working environment for industry operators.



**100+**  
**YEARS OF**  
**WELDING**  
**INNOVATION**

**WARNING**

Read and understand this entire Manual and your employer's safety practices before installing, operating, or servicing the equipment. While the information contained in this Manual represents the Manufacturer's best judgement, the Manufacturer assumes no liability for its use. Disclaimer: The images and values depicted in this manual are for illustration purposes only and may vary to actual values.

**CIGWELD BLUEVENOM  
XF195/XF200<sup>6</sup>/XF230<sup>6</sup> SiC  
OPERATING MANUAL  
NUMBER: 742051****FOR:****P/N W1400195****P/N W1400202****P/N W1400230**

Published by:

**CIGWELD Pty Ltd****CIGWELD An ESAB Brand**

71 Gower Street, Preston VIC 3072 Australia

**Customer Care:**

Tel: 1300 654 674 | Intl Tel: +61 3 9474 7400

Email: support@cigweld.com.au

 | **CIGWELD.COM.AU**

© Copyright 2025 CIGWELD Pty Ltd

All rights reserved.

Reproduction of this work, in whole or in part, without written permission of the publisher is prohibited.

The publisher does not assume and hereby disclaims any liability to any party for any loss or damage caused by any error or omission in this Manual, whether such error results from negligence, accident, or any other cause.

For Printing Material Specification refer to document 47x1915.

Publication Date: 21-05-2026

**Revision Date:**  
\_\_\_\_\_**RECORD THE FOLLOWING  
INFORMATION  
FOR WARRANTY PURPOSES:****Where Purchased:**  
\_\_\_\_\_**Purchase Date:**  
\_\_\_\_\_**Equipment Serial #:**  
\_\_\_\_\_

**BE SURE THIS INFORMATION REACHES THE OPERATOR. YOU CAN GET EXTRA COPIES FOR FREE BY DOWNLOADING FROM THE CIGWELD WEBSITE.**



### **CAUTION**

These INSTRUCTIONS are for experienced operators. If you are not fully familiar with the principles of operation and safe practices for arc welding and cutting equipment, we urge you to read our booklet, "Precautions and Safe Practices for Arc Welding, Cutting, and Gouging," Booklet 0-5407. Do NOT permit untrained persons to install, operate, or maintain this equipment. Do NOT attempt to install or operate this equipment until you have read and fully understand these instructions. If you do not fully understand these instructions, contact your supplier for further information. Be sure to read the Safety Precautions before installing or operating this equipment.

---

## **USER RESPONSIBILITY**

This equipment will perform in conformity with the description thereof contained in this manual and accompanying labels and/or inserts when installed, operated, maintained and repaired in accordance with the instructions provided. This equipment must be checked periodically. Malfunctioning or poorly maintained equipment should not be used. Parts that are broken, missing, worn, distorted or contaminated should be replaced immediately. Should such repair or replacement become necessary, the manufacturer recommends that a telephone or written request for service advice be made to the Authorised Distributor from whom it was purchased.

This equipment or any of its parts should not be altered without the prior written approval of the manufacturer. The user of this equipment shall have the sole responsibility for any malfunction which results from improper use, faulty maintenance, damage, improper repair or alteration by anyone other than the manufacturer or a service facility designated by the manufacturer.



**READ AND UNDERSTAND THE OPERATING MANUAL BEFORE INSTALLING OR OPERATING. PROTECT YOURSELF AND OTHERS!**

---

# CIGWELD

AN ESAB BRAND

## DECLARATION OF CONFORMITY

According to AS/NZS 3820:2020, Essential Safety Requirements for Electrical Equipment Radiocommunications Labelling (Electromagnetic Compatibility) Notice 2017

## TYPE OF EQUIPMENT

Arc welding power source

## TYPE DESIGNATION

BlueVenom XF195 with serial number from: ZC614YYWW####

BlueVenom XF200<sup>6</sup> with serial number from: ZC615YYWW####

BlueVenom XF230<sup>6</sup> with serial number from: ZC616YYWW####

## BRAND NAME OR TRADEMARK

CIGWELD

## MANUFACTURER OR HIS AUTHORISED REPRESENTATIVE ESTABLISHED WITHIN THE EEA NAME, ADDRESS, AND TELEPHONE NO:

CIGWELD Pty Ltd 71 Gower Street  
Preston, Victoria, Australia, 3072  
Phone: +61 3 9474 7400;  
cigweld.com.au

## THE FOLLOWING HAS BEEN USED IN THE DESIGN:

- |                             |   |
|-----------------------------|---|
| <b>AS 1674.2:2025</b>       | Safety in welding and allied processes, Part 2: Electrical                |
| <b>AS 60974.1:2020</b>      | Arc Welding Equipment, Part 1: Welding Power Sources                      |
| <b>AS/NZS 3760:2022</b>     | In-service safety inspection and testing of electrical equipment and RCDs |
| <b>EN IEC 60974-10:2021</b> | Arc Welding Equipment, Part 10: EMC requirements                          |

## ADDITIONAL INFORMATION:

Restrictive use, Class A equipment, intended for use in location other than residential. This equipment is also in compliance with the essential requirements of EU Directives 2014/30/EU and 2014/35/EU.

**BY SIGNING THIS DOCUMENT, THE UNDERSIGNED DECLARES AS MANUFACTURER, OR THE MANUFACTURER'S AUTHORISED REPRESENTATIVE, THAT THE EQUIPMENT IN QUESTION COMPLIES WITH THE SAFETY REQUIREMENTS STATED ABOVE.**

**PLACE/DATE**

**SIGNATURE**

Preston  
21-05-2026

  
Jarrod Brennan  
General Manager

# TABLE OF CONTENTS

## SECTION 1:

### ARC WELDING SAFETY INSTRUCTIONS AND WARNINGS **8**

1.01	ARC WELDING HAZARDS	8
1.02	PRINCIPAL SAFETY STANDARDS	13

## SECTION 2:

### INTRODUCTION **14**

2.01	HOW TO USE THIS MANUAL	14
2.02	EQUIPMENT IDENTIFICATION	14
2.03	RECEIPT OF EQUIPMENT	15
2.04	SYMBOL CHART	15
2.05	DESCRIPTION	16
2.06	USER RESPONSIBILITY	16
2.07	WHAT'S IN THE BOX	16
2.08	TRANSPORTING METHODS	17
2.09	DUTY CYCLE	17
2.10	SPECIFICATIONS	18
2.11	OPTIONAL ACCESSORIES	21
2.12	RELATED PRODUCTS	22

## SECTION 3:

### INSTALLATION **23**

3.01	ENVIRONMENT	23
3.02	LOCATION	23
3.03	VENTILATION	23
3.04	MAINS SUPPLY VOLTAGE REQUIREMENTS	23

3.05	GENERATORS	24
3.06	EXTENSION LEADS	24
3.07	ELECTROMAGNETIC COMPATIBILITY	24
3.08	HIGH FREQUENCY ARC INITIATION OR STABILISATION (WHERE FITTED)	25

## SECTION 4:

### OPERATION **26**

4.01	OVERVIEW	26
4.02	POWER SOURCE CONTROLS, INDICATORS AND FEATURES	27
4.03	SYSTEM SETTINGS	30
4.04	SAVE SETTINGS	31
4.05	START / END PARAMETERS	32

## SECTION 5:

### MIG (GMAW/FCAW) WELDING **33**

5.01	MIG MODE SETUP	33
5.02	MIG - MODE PARAMETERS	34
5.03	MIG - WELD PARAMETERS	36
5.04	MIG-ARC PARAMETERS	39
5.05	SHIELDING GAS REGULATOR/ FLOWMETER OPERATING INSTRUCTIONS	40
5.06	ATTACHING THE DIGITAL CONTROL MIG GUN	42
5.07	INSTALLING MIG WIRE SPOOLS	43
5.08	CHANGING INLET GUIDE FOR ALUMINIUM AND SOFT WIRES	43

5.09	<b>SPOOL HUB BRAKE</b>	<b>44</b>
5.10	<b>INSERTING WIRE INTO THE WIRE FEED MECHANISM</b>	<b>44</b>
5.11	<b>FEED ROLL PRESSURE ADJUSTMENT</b>	<b>45</b>
5.12	<b>CHANGING THE FEED ROLLS</b>	<b>45</b>
5.13	<b>MIG GUN POLARITY LEAD</b>	<b>46</b>
5.14	<b>GAS MIG (GMAW) SOLID WIRE SETUP</b>	<b>46</b>
5.15	<b>GASLESS MIG (FCAW) WELDING WITH FLUXCORED WIRE</b>	<b>48</b>
5.16	<b>SPOOL GUN SETUP</b>	<b>49</b>
5.17	<b>PUSH PULL GUN SETUP</b>	<b>50</b>
5.18	<b>MIG WELDING</b>	<b>51</b>
5.19	<b>CIGWELD MIG WIRE SELECTION CHART</b>	<b>52</b>
5.20	<b>MIG WELDING TROUBLESHOOTING</b>	<b>53</b>
5.21	<b>MIG WELDING PROBLEMS</b>	<b>56</b>

**SECTION 6:****TIG (GTAW) WELDING 58**

6.01	<b>TIG MODE SETUP</b>	<b>58</b>
6.02	<b>TIG - MODE PARAMETERS</b>	<b>59</b>
6.03	<b>TIG - WELD PARAMETERS</b>	<b>61</b>
6.04	<b>TIG WELDING BASICS</b>	<b>65</b>
6.05	<b>TIG REGULATOR/ FLOWMETER</b>	<b>68</b>
6.06	<b>TIG WELDING</b>	<b>70</b>
6.07	<b>TIG WELDING ISSUES - CAUSE &amp; REMEDY</b>	<b>71</b>

**SECTION 7:****STICK (MMA) WELDING 73**

7.01	<b>STICK (MMA) MODE SETUP</b>	<b>73</b>
7.02	<b>STICK (MMA) - MODE PARAMETERS</b>	<b>74</b>
7.03	<b>STICK (MMA) - WELD PARAMETERS</b>	<b>75</b>
7.04	<b>STICK WELDING BASICS</b>	<b>76</b>
7.05	<b>STICK WELDING</b>	<b>79</b>
7.06	<b>STICK (MMA) - WELD PARAMETERS</b>	<b>81</b>

**SECTION 8:****ROUTINE SERVICE REQUIREMENTS AND POWER SOURCE PROBLEMS 83**

8.01	<b>A ROUTINE MAINTENANCE &amp; INSPECTION</b>	<b>83</b>
8.02	<b>CLEANING THE WELDING POWER SOURCE</b>	<b>84</b>
8.03	<b>CLEANING THE FEED ROLLS</b>	<b>84</b>
8.04	<b>BASIC TROUBLESHOOTING</b>	<b>84</b>
8.05	<b>BLUEVENOM SiC ERROR CODES</b>	<b>85</b>

**SECTION 9:****MIG GUN FRONT END CONSUMABLES 86**

9.01	<b>MIG GUN CONSUMABLES</b>	<b>86</b>
9.02	<b>TIG TORCH CONSUMABLES</b>	<b>89</b>

**SECTION 10:****WARRANTY 92**

# SECTION 1: ARC WELDING SAFETY INSTRUCTIONS AND WARNINGS



## **WARNING**

**PROTECT YOURSELF AND OTHERS FROM POSSIBLE SERIOUS INJURY OR DEATH. KEEP CHILDREN AWAY. PACEMAKER WEARERS KEEP AWAY UNTIL CONSULTING YOUR DOCTOR. DO NOT LOSE THESE INSTRUCTIONS. READ OPERATING/INSTRUCTION MANUAL BEFORE INSTALLING, OPERATING OR SERVICING THIS EQUIPMENT.**

Welding products and welding processes can cause serious injury or death, or damage to other equipment or property, if the operator does not strictly observe all safety rules and take precautionary actions.

Safe practices have developed from past experience in the use of welding and cutting machinery/equipment. These practices must be learned through study and training before using this equipment. Some of these practices apply to equipment connected to power lines; other practices apply to engine driven equipment. Anyone not having extensive training in welding and cutting practices should not attempt to weld.

Safe practices are outlined in the Australian Standard AS 1674.2:2025 entitled: Safety in welding and allied processes Part 2: Electrical. This publication and other guides as to what you should learn before operating this equipment are listed at the end of these safety precautions.

**HAVE ALL INSTALLATION, OPERATION, MAINTENANCE, AND REPAIR WORK PERFORMED ONLY BY QUALIFIED PEOPLE.**

## 1.01 ARC WELDING HAZARDS



### WARNING

**ARC RAYS can burn eyes and skin; NOISE can damage hearing.**

Arc rays from the welding process produce intense heat and strong ultraviolet rays that can burn eyes and skin. Noise from some processes can damage hearing.

## ARC RAYS AND NOISE

1. Use a Welding Helmet or Welding Faceshield fitted with a proper shade of filter (see ANSI Z49.1 and AS 1674 listed in Safety Standards) to protect your face and eyes when welding or watching the welding operation.
2. Wear approved safety glasses. Side shields recommended.
3. Use protective screens or barriers to protect others from flash and glare; warn others not to watch the arc.
4. Wear protective clothing made from durable, flame-resistant material (wool and leather) and foot protection.
5. Use approved ear plugs or ear muffs if noise level is high.
6. Never wear contact lenses while welding.



### WARNING

**ELECTRIC SHOCK can kill.**

Touching live electrical parts can cause fatal shocks or severe burns. The electrode and work circuit is electrically live whenever the output is on. The input power circuit and machine internal circuits are also live when power is on.

In semiautomatic or automatic wire welding, the wire, wire reel, drive roll housing, and all metal parts touching the welding wire are electrically live. Incorrectly installed or improperly grounded equipment is a hazard.

## ELECTRIC SHOCK

1. Do not touch live electrical parts.
2. Wear dry, hole-free insulating gloves and body protection.
3. Insulate yourself from work and ground using dry insulating mats or covers.
4. Disconnect input power or stop engine before installing or servicing this equipment. Lock input power disconnect switch open, or remove line fuses so power cannot be turned on accidentally.
5. Properly install and ground this equipment according to its Operating Manual and national, state, and local codes.
6. Turn off all equipment when not in use. Disconnect power to equipment if it will be left unattended or out of service.
7. Use fully insulated electrode holders. Never dip holder in water to cool it or lay it down on the ground or the work surface. Do not touch holders connected to two welding machines at the same time or touch other people with the holder or electrode.
8. Do not use worn, damaged, undersized, or poorly spliced cables.
9. Do not wrap cables around your body.
10. Ground the workpiece to a good electrical (earth) ground.
11. Do not touch electrode while in contact with the work (ground) circuit.
12. Use only well-maintained equipment. Repair or replace damaged parts at once.
13. In confined spaces or damp locations, do not use a welder with AC output unless it is equipped with a voltage reducer. Use equipment with DC output.
14. Wear a safety harness to prevent falling if working above floor level.
15. Keep all panels and covers securely in place.

**RECOMMENDED PROTECTIVE FILTERS FOR ELECTRIC WELDING**

Description of process	Approximate range of welding current in amps	Minimum shade number of filter(s)
Manual Metal Arc Welding - covered electrodes (MMAW)	Less than or equal to 100	8
	100 to 200	10
	200 to 300	11
	300 to 400	12
	Greater than 400	13
Gas Metal Arc Welding (GMAW) (MIG) other than Aluminium and Stainless Steel	Less than or equal to 150	10
	150 to 250	11
	250 to 300	12
	300 to 400	13
	Greater than 400	14
Gas Metal Arc Welding (GMAW) (MIG) Aluminium and Stainless Steel	Less than or equal to 250	12
	250 to 350	13
Gas Tungsten Arc Welding (GTAW) (TIG)	Less than or equal to 100	10
	100 to 200	11
	200 to 250	12
	250 to 350	13
	Greater than 350	14
Flux-cored Arc Welding (FCAW) - with or without shielding gas	Less than or equal to 300	11
	300 to 400	12
	400 to 500	13
	Greater than 500	14
Air - Arc Gouging	Less than or equal to 400	12
Plasma - Arc Cutting	50 to 100	10
	100 to 400	12
	400 to 800	14
Plasma - Arc Spraying	—	15
Plasma - Arc Welding	Less than or equal to 20	8
	20 to 100	10
	100 to 400	12
	400 to 800	14
Submerged - Arc Welding	—	2(5)
Resistance Welding	—	Safety Spectacles or eye shield

Refer to standard AS/NZS 1338.1:2012 for comprehensive information regarding the above table.

## FUMES AND GASES



### WARNING

#### FUMES & GASES CAN BE HAZARDOUS TO YOUR HEALTH.

Welding produces fumes and gases. Breathing these fumes and gases can be hazardous to your health.

1. Keep your head out of the fumes. Do not breathe the fumes.
2. If inside, ventilate the area and/or use exhaust at the arc to remove welding fumes and gases.
3. If ventilation is poor, use an approved air-supplied respirator.
4. Read the Material Safety Data Sheets (MSDSs) and the manufacturer's instruction for metals, consumables, coatings, and cleaners.
5. Work in a confined space only if it is well ventilated, or while wearing an air-supplied respirator. Shielding gases used for welding can displace air causing injury or death. Be sure the breathing air is safe.
6. Do not weld in locations near degreasing, cleaning, or spraying operations. The heat and rays of the arc can react with vapours to form highly toxic and irritating gases.
7. Do not weld on coated metals, such as galvanized, lead, or cadmium plated steel, unless the coating is removed from the weld area, the area is well ventilated, and if necessary, while wearing an air-supplied respirator. The coatings and any metals containing these elements can give off toxic fumes if welded.

## WELDING



### WARNING

#### WELDING CAN CAUSE FIRE OR EXPLOSION.

Sparks and spatter fly off from the welding arc. The flying sparks and hot metal, weld spatter, hot workpiece, and hot equipment can cause fires and burns. Accidental contact of electrode or welding wire to metal objects can cause sparks, overheating, or fire.

1. Protect yourself and others from flying sparks and hot metal.
2. Do not weld where flying sparks can strike flammable material.
3. Remove all flammables within 35ft (10.7m) of the welding arc. If this is not possible, tightly cover them with approved covers.
4. Be alert that welding sparks and hot materials from welding can easily go through small cracks and openings to adjacent areas.
5. Watch for fire, and keep a fire extinguisher nearby.
6. Be aware that welding on a ceiling, floor, bulkhead, or partition can cause fire on the hidden side.
7. Do not weld on closed containers such as tanks or drums.
8. Connect work cable to the work as close to the welding area as practical to prevent welding current from travelling long, possibly unknown paths and causing electric shock and fire hazards.
9. Do not use welder to thaw frozen pipes.
10. Remove stick electrode from holder or cut off welding wire at contact tip when not in use.

## FLYING SPARKS AND HOT METAL



### WARNING

#### FLYING SPARKS & HOT METAL CAN CAUSE INJURY.

Sparks and spatter fly off from the welding arc. The flying sparks and hot metal, weld spatter, hot workpiece, and hot equipment can cause fires and burns. Accidental contact of electrode or welding wire to metal objects can cause sparks, overheating, or fire.

1. Wear approved face shield or safety goggles. Side shields recommended.
2. Wear proper body protection to protect skin.

## CYLINDERS



### WARNING

#### CYLINDERS CAN EXPLODE IF DAMAGED.

Shielding gas cylinders contain gas under high pressure. If damaged, a cylinder can explode. Since gas cylinders are normally part of the welding process, be sure to treat them carefully.

1. Protect compressed gas cylinders from excessive heat, mechanical shocks, and arcs.
2. Install and secure cylinders in an upright position by chaining them to a stationary support or equipment cylinder rack to prevent falling or tipping.
3. Keep cylinders away from any welding or other electrical circuits.
4. Never allow a welding electrode to touch any cylinder.
5. Use only correct shielding gas cylinders, regulators, hoses, and fittings designed for the specific application; maintain them and associated parts in good condition.
6. Turn face away from valve outlet when opening cylinder valve.
7. Keep protective cap in place over valve except when cylinder is in use or connected for use.
8. Read and follow instructions on compressed gas cylinders, associated equipment, and CGA publication P-1 listed in Safety Standards.

## MOVING PARTS



### WARNING

Moving parts can cause injury.

**Moving parts, such as fans, rotors, and belts can cut fingers and hands and catch loose clothing.**

1. Keep all doors, panels, covers, and guards closed and securely in place.
2. Stop engine before installing or connecting unit.
3. Have only qualified people remove guards or covers for maintenance and troubleshooting as necessary.
4. To prevent accidental starting during servicing, disconnect negative (-) battery cable from battery.
5. Keep hands, hair, loose clothing, and tools away from moving parts.
6. Reinstall panels or guards and close doors when servicing is finished and before starting engine.



### WARNING

This product, when used for welding or cutting, produces fumes or gases which contain chemicals known to the State of California to cause birth defects and, in some cases, cancer. (California Health & Safety code Sec. 25249.5 et seq.)



### NOTE

Considerations About Welding and The Effects of Low Frequency Electric and Magnetic Fields.



## WARNING

The procedures below are among those also normally recommended for pacemaker wearers. Consult your doctor for complete information.

The following is a quotation from the General Conclusions Section of the U.S. Congress, Office of Technology Assessment, Biological Effects of Power Frequency Electric & Magnetic Fields - Background Paper, OTA-BP-E-63 (Washington, DC: U.S. Government Printing Office, May 1989): "...there is now a very large volume of scientific findings based on experiments at the cellular level and from studies with animals and people which clearly establish that low frequency magnetic fields and interact with, and produce changes in, biological systems. While most of this work is of very high quality, the results are complex. Current scientific understanding does not yet allow us to interpret the evidence in a single coherent framework. Even more frustrating, it does not yet allow us to draw definite conclusions about questions of possible risk or to offer clear science-based advice on strategies to minimize or avoid potential risks."

### To reduce magnetic fields in the workplace, use the following procedures:

1. Keep cables close together by twisting or taping them.
2. Arrange cables to one side and away from the operator.
3. Do not coil or drape cable around the body.
4. Keep welding power source and cables as far away from body as practical.

## 1.02 PRINCIPAL SAFETY STANDARDS

Safety in welding and allied processes Part 1: Fire Precautions, AS 1674.1:2025 from SAI Global Limited, [www.saiglobal.com](http://www.saiglobal.com).

Safety in welding and allied processes Part 2: Electrical, AS 1674.2:2025 from SAI Global Limited, [www.saiglobal.com](http://www.saiglobal.com).

Filters for eye protectors - Filters for protection against radiation generated in welding and allied operations AS/NZS 1338.1:2012 from SAI Global Limited, [www.saiglobal.com](http://www.saiglobal.com).

Welding Processes, Code of Practice, JULY 2020 - Safe Work Australia. This document provides "Practical guidance on how to manage health and safety risks associated with welding". **The latest version is available free of charge at:** <https://www.safeworkaustralia.gov.au/doc/model-code-practice-welding-processes>.

### Other International Standards and Codes of Practice

Safety in Welding and Cutting, ANSI Standard Z49.1, from American Welding Society, 550 N.W. LeJeune Rd., Miami, FL 33126.

Safety and Health Standards, OSHA 29 CFR 1910, from Superintendent of Documents, U.S. Government Printing Office, Washington, D.C. 20402.

Recommended Safe Practices for the Preparation for Welding and Cutting of Containers That Have Held Hazardous Substances, American Welding Society Standard AWS F4.1, from American Welding Society, 550 N.W. LeJeune Rd., Miami, FL 33126.

National Electrical Code, NFPA Standard 70, from National Fire Protection Association, Batterymarch Park, Quincy, MA 02269.

Safe Handling of Compressed Gases in Cylinders, CGA Pamphlet P-1, from Compressed Gas Association, 1235 Jefferson Davis Highway, Suite 501, Arlington, VA 22202.

Code for Safety in Welding and Cutting, CSA Standard W117.2, from Canadian Standards Association, Standards Sales, 178 Rexdale Boulevard, Rexdale, Ontario, Canada M9W 1R3.

Safe Practices for Occupation and Educational Eye and Face Protection, ANSI Standard Z87.1, from American National Standards Institute, 1430 Broadway, New York, NY 10018.

Cutting and Welding Processes, NFPA Standard 51B, from National Fire Protection Association, Batterymarch Park, Quincy, MA 02269.

# SECTION 2: INTRODUCTION

## 2.01 HOW TO USE THIS MANUAL

This Operating Manual only applies to the Part Numbers listed on page 3. To ensure safe operation, read the entire manual, including the chapter on safety instructions and warnings.

Throughout this manual, the words WARNING, CAUTION, and NOTE may appear. Pay particular attention to the information provided under these headings. These special annotations are easily recognized as follows:



### NOTE

An operation, procedure, or background information which requires additional emphasis or is helpful in efficient operation of the system.



### CAUTION

A procedure which, if not properly followed, may cause damage to the equipment.



### WARNING

An operation, procedure, or background information which requires additional emphasis or is helpful in efficient operation of the system.



### ELECTRICAL WARNING

Gives information regarding possible electrical shock injury. Warnings will be enclosed in a box such as this.



### DANGER

Means immediate hazards which, if not avoided, will result in immediate, serious personal injury or loss of life.

Additional copies of this manual may be purchased by contacting CIGWELD at the address and phone number for your location listed in the inside back cover of this manual. Include the Operating Manual number and equipment identification numbers.

Electronic copies of this manual can also be downloaded at no charge in Acrobat PDF format by going to the CIGWELD web site listed below and clicking on the Literature Library link:

[cigweld.com.au](http://cigweld.com.au)

## 2.02 EQUIPMENT IDENTIFICATION

The units identification number (specification or part number), model, and serial number are located on the Data Plate which is fixed to the bottom of the welding machine. In some cases, the Data Plate may be attached to the rear panel. Equipment which does not have a control panel such as cable assemblies are identified only by the specification or part number printed on the shipping container. Record these numbers on the bottom of page 3 for future reference.

## 2.03 RECEIPT OF EQUIPMENT

When you receive the equipment, check it against the invoice to confirm it is complete and inspect the equipment for possible damage due to shipping. If there is any damage, notify the carrier immediately to file a claim. Furnish complete information concerning damage claims or shipping errors to the location listed on the back cover of this manual. Include all equipment identification numbers, as described above, along with a full description of the parts in error.

Move the equipment to the installation site before unboxing the unit. Use care to avoid damaging the equipment when using knives, breaker bars, hammers, etc, to unbox the machine and its accessories.

## 2.04 SYMBOL CHART

Note that only some of these symbols will appear on your model.

	ON		THREE PHASE		PURGING OF GAS
	OFF		THREE PHASE STATIC FREQUENCY CONVERTER-TRANSFORMER-RECTIFIER		CONTINUOUS WELD MODE
	DANGEROUS VOLTAGE		REMOTE		SPOT WELD MODE
	INCREASE/DECREASE	X	DUTY CYCLE		SPOT TIME
	CIRCUIT BREAKER	%	PERCENTAGE		PREFLOW TIME
	AC AUXILIARY POWER		SHIELDED METAL ARC WELDING (SMAW)		POSTFLOW TIME
	FUSE		GAS METAL ARC WELDING (GMAW)		PLATE THICKNESS
<b>A</b>	AMPERAGE		GAS TUNGSTEN ARC WELDING (GTAW)		OUTPUT CURRENT
<b>V</b>	VOLTAGE		AIR CARBON ARC CUTTING (CAC-A)		2-YEAR WARRANTY
<b>Hz</b>	HERTZ (CYCLES/SEC)	<b>b</b>	CONSTANT CURRENT		BURNBACK TIME
<b>f</b>	FREQUENCY		CONSTANT VOLTAGE OR CONSTANT POTENTIAL		DISTURBANCE IN GROUND SYSTEM
<b>-</b>	NEGATIVE		HIGH TEMPERATURE	<b>IP M</b>	INCHES PER MINUTE
<b>+</b>	POSITIVE		FAULT INDICATION	<b>MPM</b>	METRES PER MINUTE
	DIRECT CURRENT (DC)		ARC FORCE		SPOOL GUN
	PROTECTIVE EARTH (GROUND)		TOUCH START (GTAW)		PUSH PULL GUN
	LINE		VARIABLE INDUCTANCE		SINGLE PULSE
	LINE CONNECTION		VOLTAGE INPUT		DOUBLE PULSE
	AUXILIARY POWER		WIRE FEED FUNCTION		PULSE FREQ. (PULSE SPEED)
<b>115V 15A</b> 	RECEPTACLE RATING-AUXILIARY POWER		WIRE FEED TOWARDS WORKPIECE WITH OUTPUT VOLTAGE OFF		PULSE BASE CURRENT
<b>1</b> 	SINGLE PHASE		WELDING GUN		PULSE WIDTH

## 2.05 DESCRIPTION

Introducing the **BlueVenom SiC** range— high-performing multi-process welders powered by the latest **Silicon Carbide (SiC) Inverter** technology, engineered to deliver consistent results across a broad range of materials and applications.

Their exceptional versatility allows smooth transitions from everyday Mild Steel fabrication to precision ‘TIG-like’ showcase welds, supported by up to six intuitive operating modes: **MIG, MIG Single Pulse, MIG Double Pulse, DC TIG, AC TIG\***, and **Stick (with Pulse)**.

Powered by a standard **15A, single-phase 230V supply**, the BlueVenom SiC range is further enhanced with **Power Factor Correction (PFC)** technology. Ensuring improved energy efficiency and stable performance, even when operating with extended cable lengths.

Navigate with ease directly from the intuitive **5” Full Colour Touchscreen**, accessing all your parameters through one neat layout at any moment. Set your parameters synergically in tune with plate thickness or tweak them to suit your welding style.

Developed with advanced **Silicon Carbide (SiC) Inverter** technology, the BlueVenom SiC range is engineered to handle your next project with confidence. Delivering superior efficiency in a compact, reliable design by minimizing power losses, enhancing arc stability, and optimizing thermal performance, resulting in smoother welds and an extended machine life.

*\*AC TIG not available on the BlueVenom XF195 SiC.*

## 2.06 USER RESPONSIBILITY

This equipment will perform safely and reliably when installed, operated and maintained in accordance with the instructions herewith. Periodic checks are recommended as defective or poorly maintained equipment should not be used. Broken, missing, severely worn, distorted or contaminated parts should be replaced immediately.

Should a repair or replacement become necessary, it is recommended that the Authorised Distributor from whom the equipment was purchased, be contacted for service advice. The owner or user of this equipment shall have the responsibility for any malfunction which results from improper use, damage, faulty maintenance or repair/alteration by other than CIGWELD or an accredited service provider.



### NOTE

Refer to the complete Warranty Schedule at the back of the manual.

## 2.07 WHAT'S IN THE BOX

### BlueVenom XF195 SiC (Part No. W1400195)

- BlueVenom XF195 SiC 5in1 Power Source
- 3m NEXARC DGX24 MIG Gun with 4-Button Control, BZ24 Style
- DIMEX ELITE 4m 17F ‘Flex Head’ TIG Torch with Trigger Button and Remote Current Control
- Fitted consumables on MIG gun & TIG torch
- 200A Twist lock Electrode Holder with 3m Lead
- 3m Quick Connect Gas Hose
- 200A Earth Clamp with 3m Lead
- BlueJet Regulator/Flowmeter
- Mild Steel & Nylon Liner, Inlet/Outlet Guides
- Feedrolls: 0.8/0.9mm (x2) Knurled (Fitted), 0.8/0.9mm V (x2), 1.0/1.2mm U (x2)
- Operating Manual

**BlueVenom XF200<sup>6</sup> SiC (Part No. W1400202)**

- BlueVenom XF200<sup>6</sup> SiC 6in1 Power Source
- 3m NEXARC DGX24 MIG Gun with 4-Button Control, BZ24 Style
- DIMEX ELITE 4m 26F 'Flex Head' TIG Torch with Trigger Button and Remote Current Control
- Fitted consumables on MIG gun & TIG torch
- 200A Twist lock Electrode Holder with 3m Lead
- 3m Quick Connect Gas Hose
- 200A Earth Clamp with 3m Lead
- BlueJet Regulator/Flowmeter
- Mild Steel & Nylon Liner, Inlet/Outlet Guides
- Feedrolls: 0.8/0.9mm (x2) Knurled (Fitted), 0.8/0.9mm V (x2), 1.0/1.2mm U (x2)
- Operating Manual

**BlueVenom XF230<sup>6</sup> SiC (Part No. W1400230)**

- BlueVenom XF230<sup>6</sup> SiC 6in1 Power Source
- 3m NEXARC DGX36 MIG Gun with 4-Button Control, BZ36 Style
- DIMEX ELITE 4m 24F 'Flex Head' TIG Torch with Trigger Button and Remote Current Control
- Fitted consumables on MIG gun & TIG torch
- 250A Twist lock Electrode Holder with 3m Lead
- 3m Quick Connect Gas Hose
- 250A Earth Clamp with 3m Lead
- BlueJet Regulator/Flowmeter
- Mild Steel & Nylon Liner, Inlet/Outlet Guides
- Feedrolls: 0.8/0.9mm (x2) Knurled (Fitted), 0.8/0.9mm V (x2), 1.0/1.2mm U (x2)
- Operating Manual

**2.08 TRANSPORTING METHODS**

This unit is equipped with a handle for carrying purposes.

**WARNING**

**FALLING EQUIPMENT** can cause serious personal injury and equipment damage.

- Lift unit with handle on top of case.
- Use handcart or similar device of adequate capacity.
- If using a forklift vehicle, place and secure unit on a proper skid before transporting.

**2.09 DUTY CYCLE**

The rated duty cycle of a Welding Power Source, is a statement of the time it may be operated at its rated welding current output without exceeding the temperature limits of the insulation of the component parts. To explain the 10 minute duty cycle period the following example is used. Suppose a Welding Power Source is designed to operate at a 15% duty cycle, 90 amperes at 23.6 volts. This means that it has been designed and built to provide the rated amperage (90A) for 1.5 minutes, i.e. arc welding time, out of every 10 minute period (15% of 10 minutes is 1.5 minutes). During the other 8.5 minutes of the 10 minute period the Welding Power Source must idle and allowed to cool.

## 2.10 SPECIFICATIONS

DESCRIPTION	BLUEVENOM XF195 SiC
Packaged Part Number	W1400195
Power Source Dimensions	(L) 650mm x (W) 220mm x (H) 410mm
Power Source Weight	18kg
Cooling	Fan Cooled
Welder Type	Multi Process Inverter Power Source
Standards	AS 60974.1:2020 EN IEC 60974-10:2021
Number of Phases	Single Phase
Nominal Supply Voltage	230 VAC $\pm$ 10%
Nominal Supply Frequency	50/60Hz
Welding Current Range (MIG mode)	30-200A
Welding Current Range (Stick mode)	10-200A
Welding Current Range (TIG Mode)	5-200A
Nominal DC Open Circuit Voltage MIG Weld Mode	72V
Open Circuit Voltage (VRD On) Stick Weld Mode	<35V
Open Circuit Voltage (VRD Off) Stick Weld Mode	72V
Effective Input Current (I <sub>1eff</sub> ) refer Note 2	14.9 Amps (230VAC)
Maximum Input Current (I <sub>1max</sub> )	28.3 Amps (230VAC)
Minimum Single Phase Generator Recommendation (refer Note 4)	8kVA@0.8PF
MIG (GMAW) Welding Output, 40°C, 10 min	200A @ 35%, 24.0V 155A @ 60%, 21.8V 120A @ 100%, 20.0V
Stick (MMAW) Welding Output, 40°C, 10 min	200A @ 28%, 28.0V 135A @ 60%, 25.4V 105A @ 100%, 24.2V
TIG (GTAW) Welding Output, 40°C, 10 min	200A @ 60%, 18.0V 155A @ 100%, 16.2V
Protection Class	IP23S

<b>DESCRIPTION</b>	<b>BLUEVENOM XF200<sup>6</sup> SiC</b>
Packaged Part Number	W1400202
Power Source Dimensions	(L) 650mm x (W) 220mm x (H) 410mm
Power Source Weight	20.6kg
Cooling	Fan Cooled
Welder Type	Multi Process Inverter Power Source
Standards	AS 60974.1:2020 EN IEC 60974-10:2021
Number of Phases	Single Phase
Nominal Supply Voltage	230 VAC $\pm$ 10%
Nominal Supply Frequency	50/60Hz
Welding Current Range (MIG mode)	30-200A
Welding Current Range (Stick mode)	10-200A
Welding Current Range (TIG Mode)	5-200A (DC) 10-200A (AC)
Nominal DC Open Circuit Voltage MIG Weld Mode	78V
Open Circuit Voltage (VRD On) Stick Weld Mode	<35V
Open Circuit Voltage (VRD Off) Stick Weld Mode	78V
Effective Input Current (I <sub>1eff</sub> ) refer Note 2	14.8 Amps (230VAC)
Maximum Input Current (I <sub>1max</sub> )	29.4 Amps (230VAC)
Minimum Single Phase Generator Recommendation (refer Note 4)	8.5kVA@0.8PF
MIG (GMAW) Welding Output, 40°C, 10 min	200A @ 32%, 24.0V 145A @ 60%, 21.3V 115A @ 100%, 19.8V
Stick (MMAW) Welding Output, 40°C, 10 min	200A @ 25%, 28.0V 130A @ 60%, 25.2V 100A @ 100%, 24.0V
TIG DC (GTAW) Welding Output, 40°C, 10 min	200A @ 35%, 18.0V 155A @ 60%, 16.2V 120A @ 100%, 14.8V
TIG AC (GTAW) Welding Output, 40°C, 10 min	200A @ 50%, 18.0V 185A @ 60%, 17.4V 145A @ 100%, 15.8V
Protection Class	IP23S

DESCRIPTION	BLUEVENOM XF230 <sup>6</sup> SiC
Packaged Part Number	W1400230
Power Source Dimensions	(L) 650mm x (W) 220mm x (H) 410mm
Power Source Weight	20.8kg
Cooling	Fan Cooled
Welder Type	Multi Process Inverter Power Source
Standards	AS 60974.1:2020 EN IEC 60974-10:2021
Number of Phases	Single Phase
Nominal Supply Voltage	230 VAC $\pm$ 10%
Nominal Supply Frequency	50/60Hz
Welding Current Range (MIG mode)	30-230A
Welding Current Range (Stick mode)	10-200A
Welding Current Range (TIG Mode)	5-230A (DC) 10-230A (AC)
Nominal DC Open Circuit Voltage MIG Weld Mode	78V
Open Circuit Voltage (VRD On) Stick Weld Mode	<35V
Open Circuit Voltage (VRD Off) Stick Weld Mode	78V
Effective Input Current (I <sub>1eff</sub> ) refer Note 2	14.9 Amps (230VAC)
Maximum Input Current (I <sub>1max</sub> )	31.7 Amps (230VAC)
Minimum Single Phase Generator Recommendation (refer Note 4)	9.5kVA@0.8PF
MIG (GMAW) Welding Output, 40°C, 10 min	230A @ 22%, 25.5V 140A @ 60%, 21.0V 110A @ 100%, 19.5V
Stick (MMAW) Welding Output, 40°C, 10 min	200A @ 25%, 28.0V 130A @ 60%, 25.2V 100A @ 100%, 24.0V
TIG DC (GTAW) Welding Output, 40°C, 10 min	230A @ 35%, 19.2V 175A @ 60%, 17.0V 135A @ 100%, 15.4V
TIG AC (GTAW) Welding Output, 40°C, 10 min	230A @ 35%, 19.2V 175A @ 60%, 17.0V 135A @ 100%, 15.4V
Protection Class	IP23S

**NOTE 1:** Due to variations that can occur in manufactured products, claimed performance, voltages, ratings, all capacities, measurements, dimensions and weights quoted are approximate only. Achievable capacities and ratings in use and operation will depend upon correct installation, use, applications, maintenance and service.

**NOTE 2:** The Effective Input Current should be used for the determination of cable size & supply requirements.

**NOTE 3:** Motor start fuses or thermal circuit breakers are recommended for this application. Check local requirements for your situation in this regard.

**NOTE 4:** Minimum Generator Recommendation at the Maximum Output Duty Cycle. Due to large variations in performance and specifications of different brands and types of generators, CIGWELD cannot guarantee full welding output power or duty cycle on every brand or type of generator. Some small generators incorporate low cost circuit breakers on their outputs. These circuit breakers usually will have a small reset button, and will trip much faster than a switchboard type circuit breaker. This may result in not being able to achieve full output or duty cycle from the power source / generator combination. For this reason we recommend a generator that incorporates switchboard type circuit breakers. CIGWELD recommends that when selecting a generator, that the particular power source / generator combination be adequately trialled to ensure the combination performs to the users expectations.

**NOTE 5:** CIGWELD reserves the right to change product performance and specifications without notice.

**NOTE 6:** If an extension lead is required to be used it is recommended to use a minimum size of 2.5mm<sup>2</sup> Heavy Duty Extension Lead. Longer extension leads may impact welding performance and operation.

## 2.11 OPTIONAL ACCESSORIES

We recommend genuine CIGWELD products. The biggest range and best quality with guaranteed performance.

PART NUMBER	DESCRIPTION
W4020012	NEXARC DGX 24, 3m BZ24 MIG Gun with 4 Button Digital Control
W4020013	NEXARC DGX 24, 4m BZ24 MIG Gun with 4 Button Digital Control
W4020014	NEXARC DGX 24, 5m BZ24 MIG Gun with 4 Button Digital Control
W4020015	NEXARC DGX 36, 3m BZ36 MIG Gun with 4 Button Digital Control
W4020016	NEXARC DGX 36, 4m BZ36 MIG Gun with 4 Button Digital Control
W4020017	NEXARC DGX 36, 5m BZ36 MIG Gun with 4 Button Digital Control
W4020003	NEXARC DGX 36 OLED, 3m BZ36 MIG Gun with 3 Button Digital Control and OLED Display
W4020004	NEXARC DGX 36 OLED, 4m BZ36 MIG Gun with 3 Button Digital Control and OLED Display
W4020005	NEXARC DGX 36 OLED, 5m BZ36 MIG Gun with 3 Button Digital Control and OLED Display
CML50609	MultiLiner Steel 0.6-0.9mm, 5.1m (No collet), Pack of 1
CML50912	MultiLiner Steel 0.9-1.2mm, 5.1m (No collet), Pack of 1
CML50916A	MultiLiner Aluminium 0.9-1.6mm, 4.5m (No collet), Pack of 1
CMLCBZ	MultiLiner Collet suit Binzel, Pack of 1
CMLCBZA	MultiLiner Alloy Collet suit Binzel, Pack of 1
FR302210V0608	Feed Roll 0.6/0.8mm V Groove (Solid Wires)
FR302210V0809	Feed Roll 0.8/0.9mm V Groove (Solid Wires)
FR302210V1012	Feed Roll 1.0/1.2mm V Groove (Solid Wires)
FR302210U0809	Feed Roll 0.8/0.9mm U Groove (Soft Wires)
FR302210U1012	Feed Roll 1.0/1.2mm U Groove (Soft Wires)
FR302210K0809	Feed Roll 0.8/0.9mm K Knurled (Flux Cored)
W7007437	Spring Steel Inlet Guide (Steel and Stainless Steel Wires)
W7007384	Nylon Inlet Guide (Soft Wires)
W4022010	DIMEX ELITE 17, 4m TIG Torch with Remote Control
W4022011	DIMEX ELITE 17F, 4m Flex Head TIG Torch with Remote Control
W4022012	DIMEX ELITE 17F, 8m Flex Head TIG Torch with Remote Control
W4022013	DIMEX ELITE 26, 4m TIG Torch with Remote Control
W4022014	DIMEX ELITE 26, 8m TIG Torch with Remote Control
W4022015	DIMEX ELITE 26F, 4m Flex Head TIG Torch with Remote Control
W4022016	DIMEX ELITE 26F, 8m Flex Head TIG Torch with Remote Control
CT1726K1	TIG Starter Kit 1 17/18/26 TIG Torches
W4021001	SGX250 Spool Gun, 6m
W4021000	PPX300 Push-Pull Gun, 8m
W4015826	CIGWELD Foot Pedal, 8m
W7004913	Quick Connect Shielding Gas Hose, 3m
210254	BlueJet Argon Regulator/Flowmeter, 45LPM, 2 Gauge
201031	CutSkill Argon Regulator/Flowmeter, 30LPM
CWPLIER	CIGWELD MIG Plier, 8 Functions Welding Plier
W4011507	SiC Trolley
646808	FLX Welding Leadset 4m, 25mm <sup>2</sup> cable, 50mm <sup>2</sup> DINSE, 250A Twistlock Electrode Holder
646810	FLX Welding Leadset 4m, 35mm <sup>2</sup> cable, 50mm <sup>2</sup> DINSE, 400A Twistlock Electrode Holder

## 2.12 RELATED PRODUCTS

PART NUMBER	DESCRIPTION
456483M	ARC UP CMX 700PRO Premium MIG Welding Gloves - M
456483L	ARC UP CMX 700PRO Premium MIG Welding Gloves - L
456483XL	ARC UP CMX 700PRO Premium MIG Welding Gloves - XL
456488M	ARC UP CTX 700F Premium TIG Welding Gloves - M
456488L	ARC UP CTX 700F Premium TIG Welding Gloves - L
456488XL	ARC UP CTX 700F Premium TIG Welding Gloves - XL
456157M	ARC UP JTX 700 Premium Welding Jacket, Grey/Black - M
456157L	ARC UP JTX 700 Premium Welding Jacket, Grey/Black - L
456157XL	ARC UP JTX 700 Premium Welding Jacket, Grey/Black - XL
4561572XL	ARC UP JTX 700 Premium Welding Jacket, Grey/Black - 2XL
WHAMXC090F	Arcmaster XC90F Auto Darkening Welding Helmet Variable Shade 4-8 / 9-14 - Blax
WHAMXC170	Arcmaster XC70 Auto Darkening Welding Helmet Variable Shade 4-8 / 9-14 - Mayhem
646782	WeldaToolz Multi-Angle Magnet 55kg force
646785	WeldaToolz Switchable Arrow Magnet 42kg force
646770	ARC UP Welding Curtain – Dark Green, 1.8m x 1.8m
646777	ARC UP Welding Curtain – Red, 1.8m x 1.8m
646776	ARC UP Welding Curtain Frame, 1.8m x 1.8m
646801	ARC UP BTX 1800 Premium Welding Blanket, 1.8m x 1.8m
646802	ARC UP BTX 2000 Premium Welding Blanket, 2m x 2m
646803	ARC UP BTX 3000 Premium Welding Blanket, 3m x 3m
456170	ARC UP APX 100 Leather Welding Apron
457570	CX 100 Leather Welding Cushion
457571	CX 200 Aluminised Welding Cushion



**ARC UP CTX 700F Premium TIG Welding Gloves**  
P/N: 456488L (Large)



**ARC UP CMX 700PRO Premium MIG Welding Gloves**  
P/N: 456483L (Large)



**ARC UP JTX 700 Premium Welding Jacket, Grey/Black**  
P/N: 456157L (Large)



**Arcmaster XC70 Welding Helmet (Mayhem)**  
P/N: WHAMXC170



**ARC UP APX 100 Leather Welding Apron**  
P/N: 456170



**CX 200 Aluminised Welding Cushion**  
P/N: 457571

# SECTION 3: INSTALLATION

## 3.01 ENVIRONMENT

These units are designed for use in environments with increased hazard of electric shock.

A. Examples of environments with increased hazard of electric shock are:

1. In locations in which freedom of movement is restricted, so that the operator is forced to perform the work in a cramped (kneeling, sitting or lying) position with physical contact with conductive parts.
2. In locations which are fully or partially limited by conductive elements, and in which there is a high risk of unavoidable or accidental contact by the operator.

B. Environments with increased hazard of electric shock do not include places where electrically conductive parts in the near vicinity of the operator, which can cause increased hazard, have been insulated.

## 3.02 LOCATION

Be sure to locate the welder according to the following guidelines:

- A. In areas, free from moisture and dust.
- B. Ambient temperature between -10°C to 40°C.
- C. In areas, free from oil, steam and corrosive gases.
- D. In areas, not subjected to abnormal vibration or shock.
- E. In areas, not exposed to direct sunlight or rain.

F. Place at a distance of 300mm or more from walls or similar that could restrict natural air flow for cooling.

## 3.03 VENTILATION

Since the inhalation of welding fumes can be harmful, ensure that the welding area is effectively ventilated.

## 3.04 MAINS SUPPLY VOLTAGE REQUIREMENTS

The Mains Supply Voltage should be within  $\pm 15\%$  of the rated Mains Supply Voltage. If actual Mains Supply Voltage is outside this range Welding Current may not be available and may cause internal components to fail.

Refer to Specifications on page 18 for Supply Voltage information.

The Welding Power Source must be:

- Correctly installed, if necessary, by a qualified electrician.
- Correctly earthed (electrically) in accordance with local regulations.
- Connected to the correct size power point and fuse as per the Specifications on page 18.

**IMPORTANT NOTE!**

This product has been fitted with a supply plug as indicated in Section 2.10. Note that the welding output range applicable with the fitted supply plug is detailed in Section 2.10.

**WARNING**

Any electrical work must be carried out by a qualified Electrical Tradesperson.

**3.05 GENERATORS**

Refer to Note 4 on page 20 for recommendations when using with a Generator.

**3.06 EXTENSION LEADS**

If an extension lead is required to be used it is recommended to use a minimum size of 2.5mm<sup>2</sup> Heavy Duty Extension Lead. Longer extension leads may impact welding performance and operation.

**3.07 ELECTROMAGNETIC COMPATIBILITY****WARNING**

Extra precautions for Electromagnetic Compatibility may be required when this Welding Power Source is used in a domestic situation.

**A. INSTALLATION AND USE - USERS RESPONSIBILITY**

The user is responsible for installing and using the welding equipment according to the manufacturer's instructions. If electromagnetic disturbances are detected then it shall be the responsibility of the user of the welding equipment to resolve the situation with the technical assistance of the manufacturer. In some cases this remedial action may be as simple as earthing the welding circuit. In other cases it could involve constructing an electromagnetic screen enclosing the Welding Power Source and the work, complete with associated input filters. In all cases, electromagnetic disturbances shall be reduced to the point where they are no longer troublesome.

**B. ASSESSMENT OF AREA**

Before installing welding equipment, the user shall make an assessment of potential electromagnetic problems in the surrounding area. The following shall be taken into account

1. Other supply cables, control cables, signalling and telephone cables; above, below and adjacent to the welding equipment.
2. Radio and television transmitters and receivers.
3. Computer and other control equipment.
4. Safety critical equipment, e.g. guarding of industrial equipment.
5. The health of people around, e.g. the use of pacemakers and hearing aids.
6. Equipment used for calibration and measurement.
7. The time of day that welding or other activities are to be carried out.
8. The immunity of other equipment in the environment: the user shall ensure that other equipment being used in the environment is compatible: this may require additional protection measures.

The size of the surrounding area to be considered will depend on the structure of the building and other activities that are taking place. The surrounding area may extend beyond the boundaries of the premises.

**C. METHODS OF REDUCING ELECTROMAGNETIC EMISSIONS****1. Mains Supply**

Welding equipment should be connected to the mains supply according to the manufacturer's recommendations. If interference occurs, it may be necessary to take additional precautions such as filtering of the mains supply. Consideration should be given to shielding the supply cable of permanently installed welding equipment in metallic conduit or equivalent. Shielding should be electrically continuous throughout its length. The shielding should be connected to the Welding Power Source so that good electrical contact is maintained between the conduit and the Welding Power Source enclosure.

**2. Maintenance of Welding Equipment**

The welding equipment should be routinely maintained according to the manufacturer's recommendations.

All access and service doors and covers should be closed and properly fastened when the welding equipment is in operation. The welding equipment should not be modified in any way except for those changes and adjustments covered in the manufacturer's instructions. In particular, the spark gaps of arc striking and stabilising devices should be adjusted and maintained according to the manufacturer's recommendations.

### 3. Welding Cables

The welding cables should be kept as short as possible and should be positioned close together, running at or close to the floor level.

### 4. Equipotential Bonding

Bonding of all metallic components in the welding installation and adjacent to it should be considered. However Metallic components bonded to the work piece will increase the risk that the operator could receive a shock by touching the metallic components and the electrode at the same time. The operator should be insulated from all such bonded metallic components.

### 5. Earthing of the Workpiece

Where the workpiece is not bonded to earth for electrical safety, nor connected to earth because of its size and position, e.g. ship's hull or building steelwork, a connection bonding the workpiece to earth may reduce emissions in some, but not all instances. Care should be taken to prevent the earthing of the workpiece increasing the risk of injury to users, or damage to other electrical equipment. Where necessary, the connection of the workpiece to earth should be made by direct connection to the workpiece, but in some countries where direct connection is not permitted, the bonding should be achieved by suitable capacitance, selected according to national regulations.

### 6. Screening and Shielding

Selective screening and shielding of other cables and equipment in the surrounding area may alleviate problems of interference. Screening the entire welding installation may be considered for special applications.

## 3.08 HIGH FREQUENCY ARC INITIATION OR STABILISATION (WHERE FITTED)

The importance of correct installation of high frequency welding equipment cannot be over emphasized. Interference due to high frequency initiated or stabilised arc is almost invariably traced to improper installation. The following information is intended as a guide for personnel installing high frequency welding machines



### WARNING

The high frequency section of this machine has an output similar to a radio transmitter. The machine should NOT be used in the vicinity of blasting operations due to the danger of premature firing.



### WARNING

It is also possible that operation close to computer installations may cause computer malfunction.

**Direct Radiation:** Radiation from the machine can occur if the case is metal and is not properly grounded. It can occur through apertures such as open access panels. The shielding of the high frequency unit in the Power Source will prevent direct radiation if the equipment is properly grounded. Arrange cables to one side and away from the operator.

**Transmission via the Supply Lead:** Without adequate shielding and filtering, high frequency energy may be fed to the wiring within the installation (mains) by direct coupling. The energy is then transmitted by both radiation and conduction. Adequate shielding and filtering is provided in the Power Source.

**Radiation from Welding Leads:** Radiated interference from welding leads, although pronounced in the vicinity of the leads, diminishes rapidly with distance. Keeping leads as short as possible will minimise this type of interference. Looping and suspending of leads should be avoided wherever possible from body as practical.

**Re-Radiation from Unearthed Metallic Objects:** A major factor contributing to interference is reradiation from unearthed metallic objects close to the welding leads. Effective grounding of such objects will prevent re-radiation in most cases.

# SECTION 4: OPERATION

## 4.01 OVERVIEW

Standard operating procedures apply when using these Welding machines, i.e. connect work lead directly to workpiece with the spring loaded clamp. The MIG wire is fed from the spool through the feed roller system and into the MIG Gun (consult CIGWELD or the electrode wire manufacturers information for the correct polarity).

The synergic welding amperage range and plate thickness values should be used as a guide only. Current delivered to the arc is dependent on the Wire Feed Speed and welding arc voltage, and as welding arc voltage varies between different classes of MIG wire, welding current at given settings could vary accordingly to the type of MIG wire in use. The operator should use the plate thickness and welding current values as a guide, then finally adjust the current setting to suit the application, by fine tuning the WFS / Amps and Volts / Trim settings.



## 4.02 POWER SOURCE CONTROLS, INDICATORS AND FEATURES

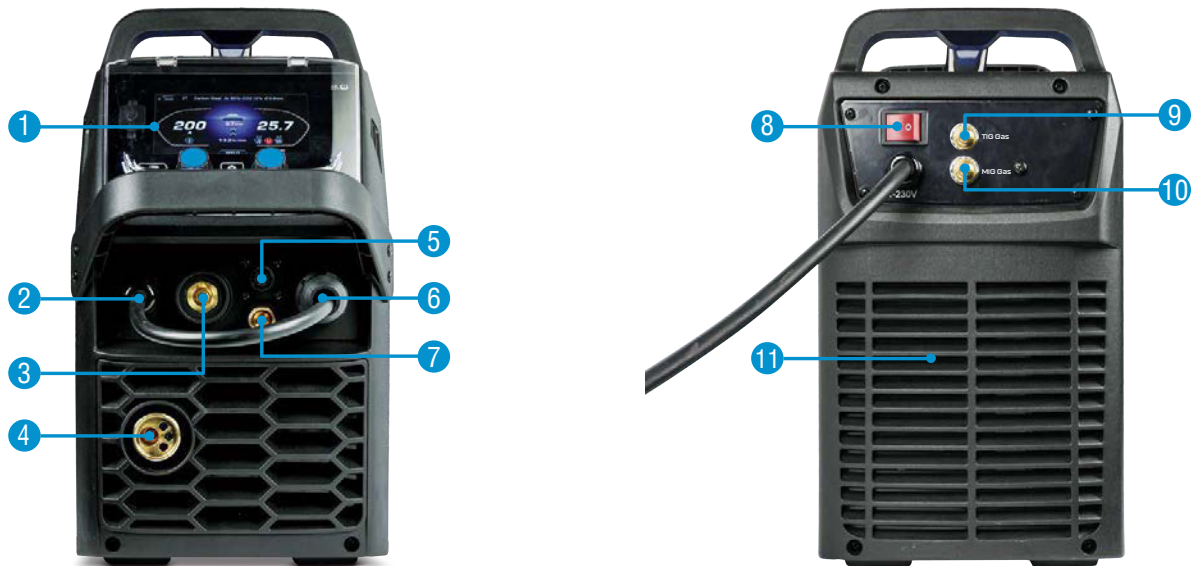

Figure 4-1: Power Source Controls, Indicators and Features

- 1 Control Panel.
- 2 MIG Gun Polarity Lead.
- 3 Negative Output Welding Terminal.
- 4 MIG Gun Adaptor (Euro Style).
- 5 Remote Control Socket 8 Pin.
- 6 Positive Output Welding Terminal.
- 7 TIG Torch Shielding Gas Outlet.
- 8 Power On/Off Switch.
- 9 TIG Shielding Gas Inlet.
- 10 MIG Shielding Gas Inlet.
- 11 Fan On Demand.

## 1 CONTROL PANEL

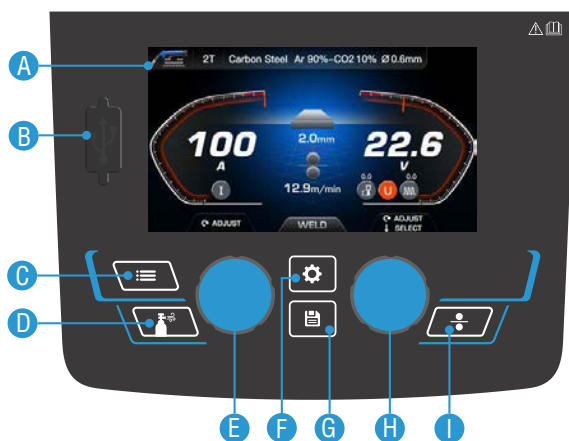

Figure 4-2: Control Panel

### A. Display

The BlueVenom XF195 SiC, XF200<sup>6</sup> SiC and XF230<sup>6</sup> SiC are equipped with a 5" full colour LCD touch-screen display, enabling you to toggle through the many features and advanced settings with ease!

### B. USB Port – Software Update

This USB Port is used to update the welding machine's software. Refer to the corresponding service manual on how to update the software.

### C. Menu Button



The Menu Button is used to cycle through the welding Mode Parameters. Press the Menu Button to display a drop down list of the available welding Mode Parameters. Rotate the Left Control Knob to scroll through the available options, press to confirm and move to the next parameter. Optionally, press the Menu Button to move to the next parameter without confirming a selection. After a short period, if no input is made to the Menu Button or Left Control Knob, the drop down list will disappear without confirming the highlighted option.

### D. Left Control Knob



The Left Control Knob is used to perform several different types of functions. In MIG Dual Pulse, MIG Pulse and MIG Synergic modes it can be rotated to adjust the Welding Current, while in MIG Manual mode it is rotated to adjust the Wire Feed Speed.

In TIG and MMA modes, or when in MIG mode's Weld Control interface; rotate to scroll through the available welding parameters and press to confirm the highlighted selection.

If the Menu button is used to expand the available Mode Parameters, it can be rotated to scroll through the selection and pressed to confirm.

### E. Right Control Knob

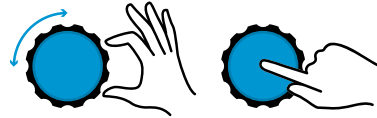

The Right Control Knob is used to perform several different types of functions. In MIG modes it can be rotated to adjust the highlighted parameter on the right side of the display, such as Welding Voltage, Arc Length, Pulse Frequency, Inductance and Voltage Trim. The knob can also be pressed to cycle through the available parameters.

In TIG and MMA modes, or when in MIG mode's Weld Control interface; rotate to adjust the highlighted parameter.

### F. Gas Purge



Press to manually purge the Shielding Gas through the MIG Gun or TIG Torch, depending on the welding mode selected.

### G. Settings Button



The Settings button performs two different types of functions. In MIG modes, press the button to display the Weld Control interface and press again to exit and return to the previous screen.

In all welding modes, press and hold the button to enter the System Settings screen, press again to exit and return to the previous screen. Refer to Section 4.03 for more information on System Settings.

H. Save Button



The Save Button is used to save and load weld settings from memory. Press to enter the Save Settings screen and press again to exit. Hold the Save Button for 3 seconds to save the current settings to memory. Refer to Section 4.04 for more information on Save Settings.

I. Wire Feed

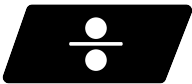

Press to manually feed wire through the Wire Feed Mechanism.

2 MIG GUN POLARITY LEAD

The polarity lead is used to connect the MIG Gun to the appropriate positive or negative output terminal (allowing polarity reversal for different welding applications). The polarity lead should be connected in to the positive welding terminal (+) when using solid steel, stainless steel or aluminium MIG wire. When using gasless wire, the polarity lead is connected to the negative welding terminal (-). If in doubt, consult the manufacturer of the electrode wire for the correct polarity. It is essential, that the male plug is inserted and turned securely to achieve a sound electrical connection.



CAUTION

Loose welding terminal connections can cause overheating and result in the male plug being fused in the twist & lock terminal, known as a DINSE Connector.

3 NEGATIVE OUTPUT WELDING TERMINAL

The negative welding terminal is used to connect the welding output of the power source to the work lead. Most General Purpose electrodes are connected with work lead (Earth Clamp) to negative. Consult the electrode manufacturer's information for the correct polarity. Welding current flows from the workpiece via this twist & lock terminal, known as a DINSE Connector to the power source. It is essential, that the male DINSE type plug is inserted and turned securely to achieve a sound electrical connection. Do not over Tighten.

CAUTION



Loose welding terminal connections can cause overheating and result in the male plug being fused in the DINSE terminal.

4 MIG GUN ADAPTOR (EURO STYLE)

The MIG Gun adaptor is the connection point for the MIG welding gun. Connect the gun by aligning and pushing the connector into the brass gun adaptor firmly and screwing the plastic nut clockwise to secure in position. To remove the MIG Gun simply reverse these directions. Refer to Section 5.06

5 REMOTE CONTROL SOCKET 8 PIN

The 8 pin Remote Control Socket is used to connect remote control devices (i.e. Spool Gun, Push Pull Gun, TIG Torch or Foot Control) to the welding power source. To make connections, align keyway, insert plug, and rotate threaded collar fully clockwise.

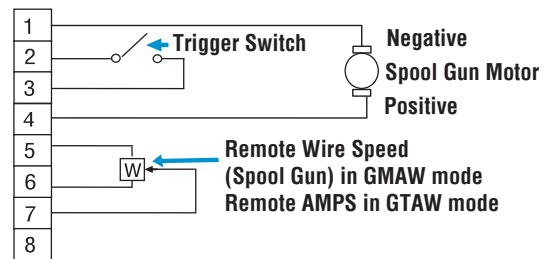
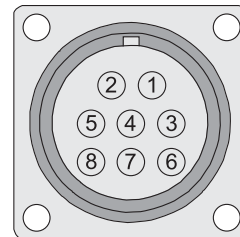

Figure 4-3: Remote Control Socket 8 Pin

Socket Pin	Description
1	Spool gun motor negative
2	Trigger Switch Input
3	Trigger Switch Input
4	Spool gun motor positive
5	Remote Control Potentiometer - Maximum
6	Remote Control Potentiometer - Minimum
7	Remote Control Potentiometer - Wiper - Wire Speed control when in MIG mode - Current control when in TIG mode
8	Not connected

## 6 POSITIVE OUTPUT WELDING TERMINAL

The positive welding terminal is used to connect the welding output of the power source to the appropriate welding accessory such as the MIG Gun (via the MIG Gun polarity lead), electrode holder lead or work lead. Positive welding current flows from the power source via this twist & lock terminal, known as a DINSE Connector. It is essential, that the male plug is inserted and turned securely to achieve a sound electrical connection.

## 7 TIG TORCH SHIELDING GAS OUTLET

The TIG Torch Shielding Gas Outlet is used to connect the TIG Torch gas hose to the machine.

## 8 POWER ON/OFF SWITCH

This switch is used to turn the unit ON/OFF. When this switch is turned ON the Colour Screen on the front panel will illuminate.



### NOTE

If the Power Source is repeatedly switched On then Off rapidly or the supply to the power source is turned On and Off rapidly it may not turn On due to inbuilt protective devices acting. If this occurs leave the Power Source On/Off switch turned to the Off position for several minutes to allow for the protective devices to reset.

## 9 MIG / TIG SHIELDING GAS INLET

The MIG/TIG Shielding Gas Inlet is a Quick Connect inlet fitting, located on the rear of the machine which is used to supply the appropriate MIG or TIG welding gas to the unit. Refer to sections 5.05 and 6.05 for more information.



### WARNING

Only Inert Shielding Gases specifically designed for welding applications should be used.

## 11 FAN ON DEMAND

The BlueVenom SiC range is fitted with a fan on demand feature. Fan on demand automatically switches the cooling fan off when it is not required. This has two main advantages; (1) to minimize power consumption, and (2) to minimise the amount of contaminants such as dust that are drawn into the power source. Note that the fan will only operate when required for cooling purposes and will automatically switch off when not required.

## 4.03 SYSTEM SETTINGS



While in any welding mode, press and hold the Setting Button for 3 seconds to enter the System Settings screen.

Rotate the Left Control Knob to highlight the desired setting, then rotate the Right Control Knob to adjust the setting.

To exit the System Settings screen, press the Settings Button.

### Language

The languages available are English, French, German, Italian and Spanish. The default factory setting for Language is English.

### Unit

Rotate the Right Control Knob anticlockwise to select Metric units and clockwise for imperial units. This setting updates the displayed Wire Feed Speed, Plate Thickness, Wire Diameter and Electrode Diameter accordingly. The default factory setting for Unit is Metric.

## Factory Reset

A Factory Reset will restore the machines system language and units to the default settings, and will remove any saved jobs from memory.

With the Factory Setting highlighted press the Right Control Knob and a screen will then appear asking to confirm. Press the Right Control Knob to restore the machine to factory settings, or press the Left Control Knob to cancel. Note that this will also reset the system language, units and remove any jobs saved to memory.

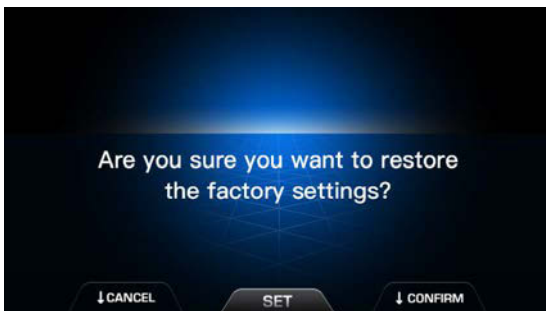

## Software Version

Below the adjustable settings the welding machine's software version is displayed.

## 4.04 SAVE SETTINGS



The BlueVenom SiC range can save a whopping 100 jobs to memory. Reduce setup time and never forget your favourite weld settings again.

To enter the Save Settings screen, press the Save Button while in any welding mode. This screen displays jobs saved to memory along with the job's parameters. For jobs saved in MIG mode, an extra interface with the Weld Parameters is displayed. Rotate the Left Control Knob to scroll through each page to see all available parameter values.

To exit the Save Settings screen, press the Save Button.

## Save Job

To save the current weld settings to memory, press and hold the Save Button until the Save Settings screen appears. The job will save to the next free memory slot. For example, if memory slots 1 and 3 are filled, the next job saved will fill memory slot 2.

If all 100 memory slots are full a screen will appear stating the memory is full and the job cannot be saved to memory.



## Load Job

To load a saved job from memory, enter the Saved Settings screen. Next rotate the Right Control Knob to scroll through the available jobs. With the desired job highlighted, press the Right Control Knob to load the job.

## Delete Job

To delete a saved job from memory, enter the Save Settings screen. Next rotate the Right Control Knob to scroll through the available jobs. With the desired job highlighted, press the Left Control Knob and a screen to confirm the job deletion will be displayed. Press the Left Control Knob to delete or the Right Control Knob to cancel.

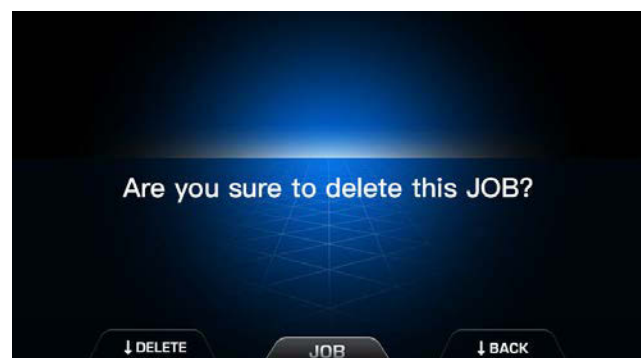

## 4.05 START / END PARAMETERS

The BlueVenom SiC range offers further control by allowing the user to adjust the start and end characteristics of a weld. When MIG welding, initial Hot Start parameters can be set to slowly raise the electrode temperature, reducing the heat stress on the weld plate. TIG welding's start parameters function similarly, with the addition of a higher Pre Current to prevent the electrode from sticking to the workpiece.

Both MIG and TIG welding feature end parameters to slowly reduce the output current, allowing the operator to fill any craters formed during welding. See Figures 4-4 and 4-5 for a detailed overview of how each parameter affects the start and end of a weld. The parameters available depend on the Trigger Mode selected, refer to Sections 5.02, 6.02 and 7.02 for details. Minimum and maximum percentage values are limited to the output current range of the welding machine. For example; on a 200A machine, if a Welding Current of 160A is set, the Hot Start Current parameter cannot be set greater than 125%.

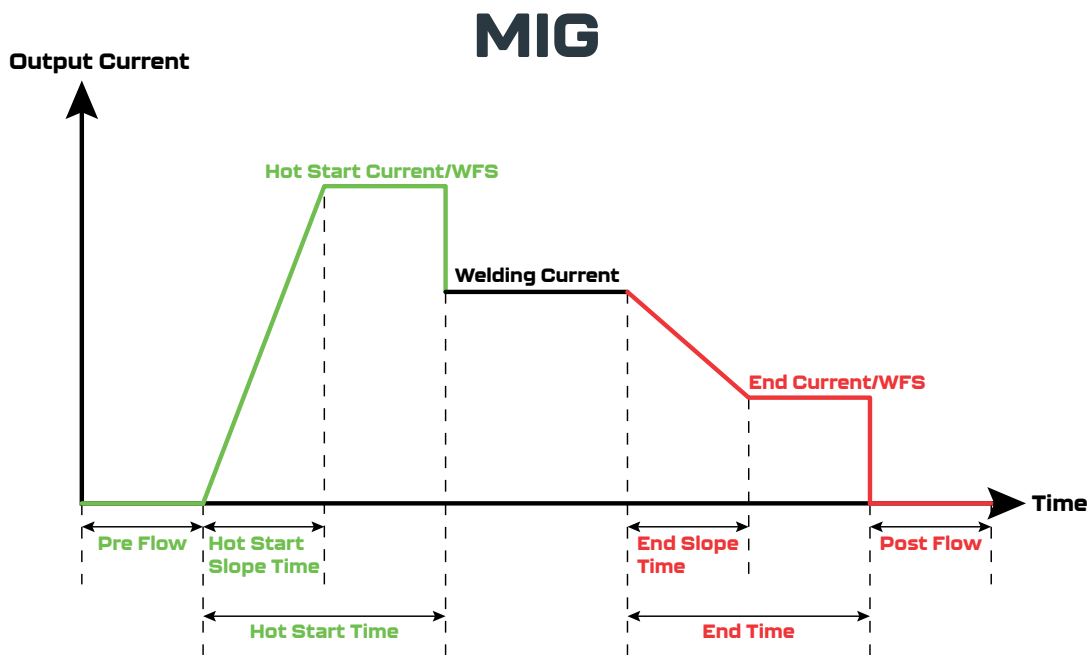

Figure 4-4: MIG - Start/End Parameters

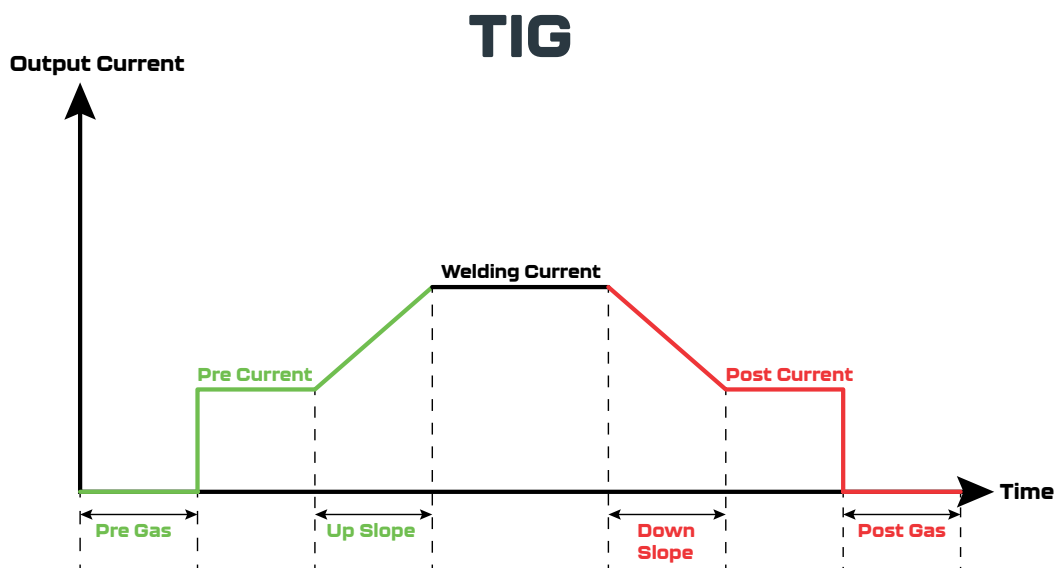

Figure 4-5: TIG - Start/End Parameters

# SECTION 5: MIG (GMAW/FCAW) WELDING

## 5.01 MIG MODE SETUP



### 1. Menu Button

Press the Menu Button to display a drop down list of the available welding Mode Parameters. Rotate the Left Control Knob to scroll through the available options, press to confirm and move to the next parameter. Optionally, press the Menu Button to move to the next parameter without confirming a selection. After a short period, if no input is made to the Menu Button or Left Control Knob, the drop down list will disappear without confirming the highlighted option.

### 2. Settings Button

Press the Settings Button to display the available Weld Parameters. Rotate the Left Control Knob to scroll through the available parameters and rotate the Right Control Knob to adjust the highlighted value.

The parameters available depend on the MIG welding mode selected, refer to Section 5.03 for the available Weld Parameters.

### 3. Mode Parameters

The Mode Parameters available depend on the MIG welding mode selected. When the MIG welding mode a second drop down list will appear. This gives the user the option to choose the type of gun being used, MIG Gun, Spool Gun, or Push Pull Gun. Use the Left Control Knob to select an option, if no option is selected after a short duration, the drop down list will disappear without confirming the highlighted option. Refer to Section 5.02 for the available MIG Mode Parameters.

### 4. Display

#### Welding Current / Wire Feed Speed



The left side of the screen displays the Welding Current in MIG Synergic, Pulse and Double Pulse modes. In MIG Manual mode the Wire Feed Speed is displayed instead.

This parameter can be adjusted by rotating the Left Control Knob. The range of the Welding Current is dependent on the Mode Parameters selected, to ensure a reliable weld for the given settings.

Wire Feed Speed & Plate Thickness

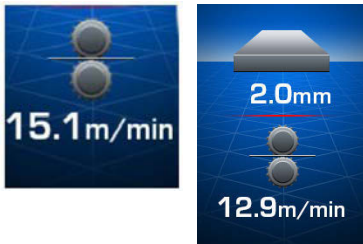

The Wire Feed Speed and Plate Thickness are displayed in the centre of the display in MIG Synergic, Pulse and Double Pulse modes. The Plate Thickness value is a recommendation based on the Welding Current and is to be used as a guide only.

Arc Control



The right side of the screen displays the available Arc Parameters, defaulting to the Welding Voltage. Rotate the Right Control Knob to adjust the highlighted parameter value and press to cycle to the next parameter. After a short period, if no input is made to the Right Control Knob the selected parameter will return to the Welding Voltage. Refer to Section 5.04 for the available MIG Arc Parameters.

5.02 MIG - MODE PARAMETERS

PARAMETER	OPTIONS AVAILABLE	DESCRIPTION
MIG Mode		<p><b>MIG Manual</b> This is the standard mode found on most MIG welders. In this mode the operator has complete control over the Wire Feed Speed and Welding Voltage.</p>
	MIG MAN.	<p><b>MIG Synergic</b> This mode utilizes pre-installed weld settings referred to as Synergic Lines. The operator simply selects the remaining Mode Parameters, and a recommended Welding current, Welding Voltage, Wire Feed Speed and Plate Thickness is set.</p>
	MIG SYN.	<p><b>MIG Pulse</b> In this mode the output current is pulsed over regular intervals, alternating between a high Peak Current and low background current.</p>
	MIG PULSE	<p><b>MIG Dual Pulse</b> This mode acts similarly to MIG Pulse, switching from a high Peak Current to a low background current with a bonus second pulse, reducing the Peak Current to a lower Base Current for a short period.</p>
	MIG DP	
Gun Type	MIG GUN	Adjusts the Wire Feed Speed based on the Gun Type being used. Refer to sections 5.16 and 5.17 for Spool Gun and Push Pull Gun installation.
	SPOOL GUN*	
	PUSH PULL GUN	
		*Spool Gun not available in MIG Pulse and MIG Double Pulse modes.

PARAMETER	OPTIONS AVAILABLE	DESCRIPTION
Trigger		<p><b>2T</b> In this mode, the trigger must remain depressed for the welding output to be active. Release the trigger switch to cease welding.</p> <p><b>4T – Latch Mode</b> In this mode the operator can press and release the trigger to begin welding. This is ideal for long weld periods to reduce strain and fatigue. Press and release the trigger again to cease welding.</p> <p>Additionally, the operator has control over the Hot Start Time and End Time parameters directly. When initiating the weld, the output will remain at the Hot Start Current as long as the trigger is held. When welding ends, the output will remain at the End Current as long as the trigger is held. Releasing the trigger will switch to the Welding Current, or stop welding respectively.</p>
	2T	
	4T	
	8T*	
	SPOT*	<p><b>8T*</b> This mode acts the same as 4T mode with an additional Secondary Welding Current/WFS and a Secondary Arc Length/Voltage. A short trigger press will switch the output to the Secondary parameters, continue to short press to alternate between the primary and secondary parameters. To cease welding, hold the trigger until the machine reduces the output to the End Current or stops welding.</p> <p><b>Spot*</b> This mode is used for Spot Welding. Press the trigger to output the Welding Current for a short interval.</p> <p><i>*Not available in MIG Dual Pulse mode</i></p>
Wire Material	Carbon Steel	
	Carbon Steel	
	Gasless	
	Carbon Steel Flux Cored	The Wire Material parameter sets the available Gas Types and Wire Diameters that can be selected based on the pre-load Synergic Lines.
	Stainless Steel	<i>*Not available in MIG Manual mode</i>
	Aluminium 5356	
	Aluminium 4043	
Silicon Bronze		

PARAMETER	OPTIONS AVAILABLE	DESCRIPTION
Gas Type	Ar 90% CO2 10%	The Gas Type parameter sets the available Wire Diameter that can be selected based on the pre-load Synergic Lines. The available options depend on the Wire Material selected.
	Ar 82% CO2 18%	
	Ar 75% CO2 25%	
	CO2 100%	<i>Not available in MIG Manual mode.</i>
Wire Diameter	NO GAS	
	0.6mm	The Wire Diameter parameter is used to set the Synergic Welding Current range, Plate Thickness, Wire Feed Speed and Welding Voltage to ensure a reliable weld. The available options depend on the Wire Material and Gas Type selected.
	0.8mm	
	0.9mm	
1.0mm		
	1.2mm	<i>Not available in MIG Manual mode.</i>

**Table 5-1: MIG Mode Parameters**

The table below shows the combinations of Wire Material, Gas Type and Wire Diameter that can be selected for the included Synergic Lines.

WIRE MATERIAL	GAS TYPE	WIRE DIAMETER
Carbon Steel	Ar 90% CO2 10%	0.6mm, 0.8mm, 0.9mm, 1.0mm, 1.2mm
	Ar 82% CO2 18%	0.8mm, 0.9mm, 1.0mm, 1.2mm
	Ar 75% CO2 25%	0.8mm, 0.9mm, 1.0mm, 1.2mm
	CO2 100%	0.8mm, 0.9mm, 1.0mm, 1.2mm
Carbon Steel Gasless	NO GAS	0.8mm, 0.9mm, 1.2mm
Carbon Steel Flux Cored	Ar 82% CO2 18%	1.2mm
	CO2 100%	1.2mm
Stainless Steel	Ar 98% CO2 2%	0.8mm, 0.9mm, 1.0mm, 1.2mm
Aluminium 5356	Ar 100%	0.9mm, 1.0mm, 1.2mm
Aluminium 5356	Ar 100%	1.0mm, 1.2mm
Silicon Bronze	Ar 100%	0.9mm, 1.2mm

**Table 5-2: Wire material, Gas type & Wire Diameter**

### 5.03 MIG - WELD PARAMETERS

PARAMETER	VALUE RANGE	DEFAULT VALUE	DESCRIPTION
Pre Flow	0.0 - 5.0s	0.1s	Pre Flow is a short burst of shielding gas prior to the arc initiating, reducing the risk of contamination at the start of the weld
Slow Feed	0 - 5	1	Slow Feed reduces the initial Wire Feed Speed prior to arcing, preventing the wire from crashing into the plate before a stable arc is created.



PARAMETER	VALUE RANGE	DEFAULT VALUE	DESCRIPTION
Spot Welding Time	0.5 -10.0s	0.5s	Spot Welding Time is the duration of the Spot Weld and can be adjusted to increase or decrease penetration to the back plate. After the time is reached the trigger must be pressed again to weld.  <i>Only available in Spot trigger mode.</i>
Hot Start Wire Speed	1.5 – 18.0m/min	1.5m/min	Hot Start Wire Speed adjusts the speed at which wire is extruded through the MIG Gun (also known as the output current) during the Hot Start period. Refer also Section 4.05.  <i>Only available in MIG Manual mode.</i>
Hot Start Voltage	12.0 – 28.0V	12.0V	Hot Start Voltage adjusts the Voltage/Arc Length during the initial Hot Start period. Refer also Section 4.05.  <i>Only available in MIG Manual mode</i>
Hot Start Current	10 – 200%	100%	Start Current adjusts the initial output current as a percentage of the Welding Current. Used to quickly warm the plate before welding commences. Refer also Section 4.05.
Hot Start Arc Length	-9.9 – 9.9	0.0	Hot Start Arc Length adjusts the Arc Length/Voltage during the initial Hot Start period. Refer also Section 4.05.
Hot Start Time	0.0 – 10.0s	0.0	Hot Start Time determines how long the End welding period will run for. This parameter is not available in 8T Trigger Mode as the operator controls the time directly. Refer also Section 4.05.
Hot Start Slope Time	0.0 – 10.0s	0.0	Hot Start Slope Time is the time it takes to increase the output current to the Hot Start Current once welding is triggered. Refer also Section 4.05.
Secondary Wire Feed Speed	1.5 - 18.0m/min	1.5m/min	Secondary Wire Feed Speed adjusts the alternate WFS/ Welding Current when using 8T Trigger Mode.  <i>Only available in MIG Manual 8T Trigger Mode.</i>
Secondary Voltage	12.0V - Max Voltage	12.0V	Secondary Voltage adjusts the alternate Welding Voltage/ Arc Length when using 8T Trigger Mode.  <i>Only available in MIG Manual 8T Trigger Mode.</i>

PARAMETER	VALUE RANGE	DEFAULT VALUE	DESCRIPTION
Secondary Current	10 - 100%	100%	<p>Secondary Current adjusts the alternate Welding Current/WFS when using 8T Trigger Mode.</p> <p><i>Only available in MIG Synergic/Pulse 8T Trigger Mode.</i></p>
Secondary Arc Length	-9.9 - 9.9	0.0	<p>Secondary Arc Length adjusts the alternate Arc Length/Voltage when using 8T Trigger Mode.</p> <p><i>Only available in MIG Synergic/Pulse 8T Trigger Mode.</i></p>
Base Current	10 - 200%	65%	<p>Base Current is the peak current of the second pulse in the Double Pulse cycle. It helps maintain the arc stability and keeps the weld pool in a controlled state while minimizing heat input. The Base Current is set at a lower value compared to the Peak Current.</p> <p><i>Only available in MIG Double Pulse welding mode.</i></p>
Base Arc Length	-9.9 – 9.9	0.0	<p>Base Current Length adjusts the Arc Length/Voltage during the final End period. Also refer to Section 5.18.</p> <p><i>Only available in MIG Double Pulse welding mode.</i></p>
Pulse Width	10 – 90%	50%	<p>Pulse Width is the time the output current remains at the Peak Current before reducing to the Base Current level, measured as a percentage of the Pulse Frequency. A lower Pulse Width results in less heat input and narrower weld beads, while a larger Pulse Width provides more heat and wider weld beads.</p> <p><i>Only available in MIG Double Pulse welding mode.</i></p>
Pulse Frequency	0.5 – 3.0Hz	1.5Hz	<p>Pulse Frequency is the number of times the double pulse occurs each second, switching between the Peak and Base Current.</p> <p><i>Only available in MIG Double Pulse welding mode.</i></p>
End Wire Speed	1.5 – 18.0m/min	1.5m/min	<p>End Wire Speed adjusts the speed at which wire is extruded through the MIG Gun (also known as the output current) during the End period. Refer also Section 4.05.</p> <p><i>Only available in MIG Manual mode.</i></p>
End Voltage	12.0 – 28.0V	12.0V	<p>End Voltage adjusts the Voltage/ Arc Length during the final End period. Refer also Section 4.05.</p> <p><i>Only available in MIG Manual mode.</i></p>

PARAMETER	VALUE RANGE	DEFAULT VALUE	DESCRIPTION
End Current	10 – 200%	100%	End Current adjusts the output current as a percentage of the Welding Current once active welding has ended. Used to fill craters as the plate cools. Refer also Section 4.05.
End Arc Length	-9.9 – 9.9	0.0	End Arc Length adjusts the Arc Length/Voltage during the final End period. Refer also Section 4.05.
End Time	0.0 – 10.0s	0.0s	End Time determines how long the End welding period will run for. This parameter is not available in 8T Trigger Mode as the operator controls the time directly. Refer also Section 4.05.
End Slope Time	0.0 – 10.0s	0.0s	End Slope Time is the time it takes to reduce the output current to the End Current once active welding has ceased. Refer also Section 4.05.
Burn Back	0 – 10	1	Burn Back extrudes extra wire through MIG Gun after welding ends. Preventing the wire from arcing to the contact tip welding itself to or inside the tip.
Post Flow	0.0 – 5.0s	2.0	Post Flow continues to emit shielding gas after welding has ended, reducing the risk of contamination at the end of the weld.

Table 5-3: MIG Weld Parameters

## 5.04 MIG - ARC PARAMETERS

PARAMETER	VALUE RANGE	DEFAULT VALUE	DESCRIPTION
Welding Voltage 	12.0 – 28.0V	12.0V	<p>This is the voltage applied to the welding arc, used to adjust the length of the welding arc. The Welding Voltage and range vary based on the set Welding Current and Mode Parameters in MIG Synergic, Pulse and Double Pulse Modes.</p> <p>Welding Voltage can only be directly adjusted in MIG Synergic and MIG Manual modes.</p>
Arc Length 	-9.9 – 9.9	0.0	<p>This is used to adjust the length of the welding arc determining the width and size of the arc's cone. As Arc Length decreases, the arc cone becomes narrower and more focused, resulting in a smaller weld bead. Conversely, as Arc Length increases, the arc cone becomes wider resulting in a larger, flatter weld bead.</p> <p><i>Only available in MIG Double Pulse and MIG Pulse welding modes.</i></p>



PARAMETER	VALUE RANGE	DEFAULT VALUE	DESCRIPTION
Pulse Frequency 	-9.9 – 9.9	0.0	Pulse Frequency adjusts the number of pulses per second in MIG Pulse mode, switching between the Welding Current and the background current. In MIG Double Pulse mode this adjusts the frequency of both the Peak and Base pulse.  <i>Only available in MIG Double Pulse and MIG Pulse welding modes.</i>
Inductance 	-10 – 10	0	Inductance adjusts the speed at which the current changes during MIG welding. A low inductance produces narrow weld beads (best for thin materials) and produces more spatter, whereas a high inductance produces a wider, flatter weld bead (best for thicker materials) with less spatter.  <i>Only available in MIG Manual and MIG Synergic welding modes.</i>
Voltage Trim 	-4.0 – 4.0	0.0	Voltage Trim increases or decreases the weld voltage from the factory Synergic value. Adjusting the Voltage Trim will adjust the Welding Voltage parameter and vice versa.  <i>Only available in MIG Synergic welding mode.</i>

Table 5-4: MIG Arc Parameters

## 5.05 SHIELDING GAS REGULATOR/FLOWMETER OPERATING INSTRUCTIONS

### SHIELDING GAS CONNECTION



#### WARNING

This equipment is designed for use with welding grade (Inert) shielding gases only.

A Preset Argon Regulator/Flowmeter and Gas Hose Kit comes with the machine plant. Connect the gas regulator onto the gas cylinder/bottle by hand, keeping the round sight gauge in the vertical position. Then tighten the nut with a spanner, but do-not over tighten. Connect the gas hose to the threaded outlet on the regulator (Figure 5-2) and tighten with a spanner. Connect the other end of the gas hose to gas inlet fitting on the rear panel of the welding machine using the supplied Quick Connect fittings (Figure 5-1). Check for any leaks with soapy water in a squeeze bottle, and look for bubbles (when the gas is on), this will highlight any gas leaks.

The gas flow (in Litres Per Minute) for shielding the molten weld metal from the atmosphere is adjustable and depends on the job and atmospheric conditions you encounter when welding. As a general rule for MIG Welding, always use a minimum of 12 LPM when welding with an amperage range of under 100Amps, a minimum of 15 LPM when the amperage is under 180Amps and a minimum of 18 LPM for welding amperages over 200Amps. A lower gas flow will affect the welding quality and cause a porous weld while high gas flow results in bigger consumption of gas.

The flow rate is measured at the middle of the float ball.

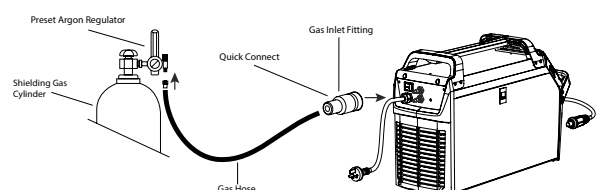

Figure 5-1: Shielding Gas Connection

## SHIELDING GAS REGULATOR/ FLOWMETER SAFETY

An Argon Regulator/Flowmeter and Gas Hose comes with the machine plant.

This Regulator/Flowmeter is designed to reduce and control high pressure gas from a cylinder to the working pressure required for the equipment using it.

If the equipment is improperly used, hazardous conditions are created that may cause accidents. It is the users responsibility to prevent such conditions. Before handling or using the equipment, understand and comply at all times with the safe practices prescribed in this instruction.

**SPECIFIC PROCEDURES** for the use of regulators/flowmeters are listed below.

1. **NEVER** subject the Regulator/Flowmeter to an inlet pressure greater than its rated inlet pressure.
2. **NEVER** pressurize a Regulator/Flowmeter that has loose or damaged parts or is in a questionable condition. **NEVER** loosen a connection or attempt to remove any part of a Regulator/Flowmeter until the gas pressure has been relieved. Under pressure, gas can dangerously propel a loose part.
3. **DO NOT** remove the Regulator/Flowmeter from a cylinder without first closing the cylinder valve and releasing gas in the Regulator/Flowmeter high and low pressure chambers.
4. **TURN OFF** When equipment is not in use for extended periods of time, shut off the gas at the cylinder valve and release the gas from the equipment.
5. **OPEN** the cylinder valve **SLOWLY**. Close after use.

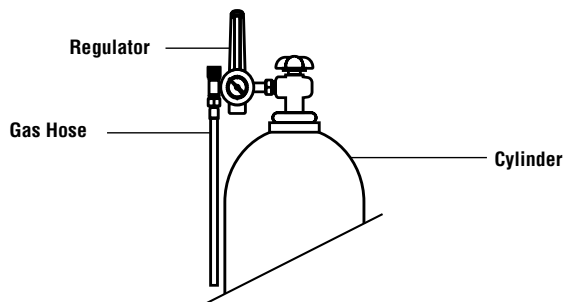

Figure 5-2: Fit Regulator/Flowmeter to Cylinder

## INSTALLATION

1. Remove cylinder valve plastic dust seal. Clean the cylinder valve outlet of impurities that may clog orifices and damage seats before connecting the Regulator/Flowmeter.  
Crack the valve (open then close) momentarily, pointing the outlet away from people and sources of ignition. Wipe with a clean lint free cloth.
2. Match Regulator/Flowmeter to cylinder. Before connecting, check that the Regulator/Flowmeter label and cylinder marking agree and that the Regulator/Flowmeter inlet and cylinder outlet match. **NEVER CONNECT** a Regulator/Flowmeter designed for a particular gas or gases to a cylinder containing any other gas.
3. Connect the Regulator/Flowmeter inlet connection to cylinder or pipeline and tighten it firmly but not excessively, with a suitable spanner.
4. Connect and tighten the outlet hose firmly and attach the hose to the welding machine with the Quick Connect fitting. Ensure no gas leakage. The flowmeter must be in the vertical position to read accurately.

## OPERATION

**With the Regulator/Flowmeter connected to cylinder or pipeline:**

1. Stand to one side of Regulator/Flowmeter and slowly open the cylinder valve. If opened quickly, a sudden pressure surge may damage internal Regulator/Flowmeter parts.
2. Since the regulator is a preset type, no adjustments to the regulator are necessary. Before opening the cylinder valve, be sure that the flow adjusting valve is in a finger-tight "OFF" position (clockwise).
3. Slowly and carefully, open the cylinder valve until the maximum pressure registers on the high pressure gauge.



### CAUTION

DO NOT purge oxidising or flammable gases in the presence of flame, lit cigarettes, or other sources of ignition or in a confined space.

Close equipment valve(s) after purging, and test all connections for leaks with a suitable leak detection solution or soapy water. Never use a flame when testing for leaks.



## CAUTION

Match Regulator/Flowmeter to cylinder. NEVER CONNECT a Regulator/Flowmeter designed for a particular gas or gases to a cylinder containing any other gas.

## ADJUSTING FLOW RATE

With the Regulator/Flowmeter ready for operation, adjust working flow rate as follows:

1. Slowly turn adjusting valve in anti-clockwise direction to open and increase until the bobbin in the flow tube indicates the required flow rate.



## NOTE

It may be necessary to re-check the shielding Gas Regulator/Flowmeter flow rate following the first weld sequence due to back pressure present within shielding gas hose assembly.

2. To reduce flow rate, allow the welding grade shielding gas to discharge from Regulator/Flowmeter by pressing the Gas Purge button on the inside of the machine, or by pressing the trigger on the MIG gun or TIG Torch. Bleed welding grade shielding gas into a well ventilated area. Turn adjusting screw clockwise, until the required flow rate is indicated on the gauge.
3. The correct flow rate will depend on the place and conditions you are working in. For indoors work shielding gas flow rate can be from 12L/min for welding thin metals (0.6-1.0mm) when using 0.6mm MIG wire, up to 15L/min when using thicker metals and using 0.8mm MIG wire. When welding near draughty doorways then the gas flow rate can go up to 18-20L/min. The tell tale sign is to ensure your finished welds do-not have porosity holes in the surface.

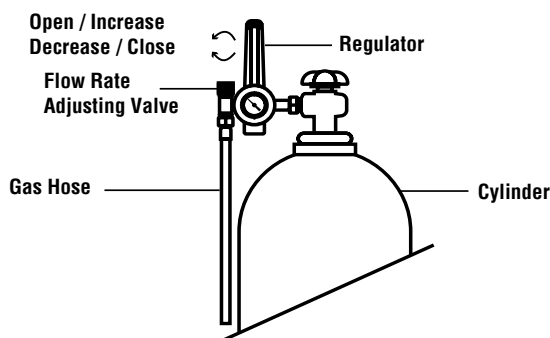

Figure 5-3: Adjust Flow Rate

## SHUTDOWN

Close cylinder valve whenever the Regulator/Flowmeter is not in use. To shut down for extended periods (more than 30 minutes).

1. Close cylinder valve tightly.
2. Remove the gas from the machine and hose by pressing the Gas Purge button on the front of the machine, or by pressing the trigger on the MIG Gun. Bleed gas into a well ventilated area.
3. After gas is drained completely turn off the machine.
4. Before transporting cylinders that are not secured on a cart designed for such purposes, remove regulators/flowmeters.



## WARNING

Moving Parts can cause injury!

## 5.06 ATTACHING THE DIGITAL CONTROL MIG GUN

The BlueVenom XF195 and XF200<sup>6</sup> SiC come with a BZ24 4 Button Digital Control MIG Gun. The BlueVenom XF230<sup>6</sup> SiC comes with a BZ36 4 Button Digital Control MIG Gun. The Digital Controls allows the user to make small adjustments to the welding parameters from the MIG gun without needing to return to the machine to adjust. Please note: adjustments can not be made whilst welding, they must be done prior to the commencement of the weld.

Fit the MIG Gun to the power source by pushing the MIG Gun connector into the MIG Gun adaptor and screwing the plastic nut clockwise to secure the MIG Gun to the MIG Gun adaptor.



- 1 Manual mode - increase Wire Feed Speed  
Synergic/Pulse modes - increase Welding Current.
- 2 Manual mode - decrease Voltage  
Synergic mode - decrease Voltage Trim  
Pulse modes - decrease Arc Length.

- 3 Manual modes - increase Voltage  
Synergic mode - increase Voltage Trim  
Pulse modes - increase Arc Length.
- 4 Manual mode - decrease Wire Feed Speed  
Synergic/Pulse modes - decrease Welding Current.

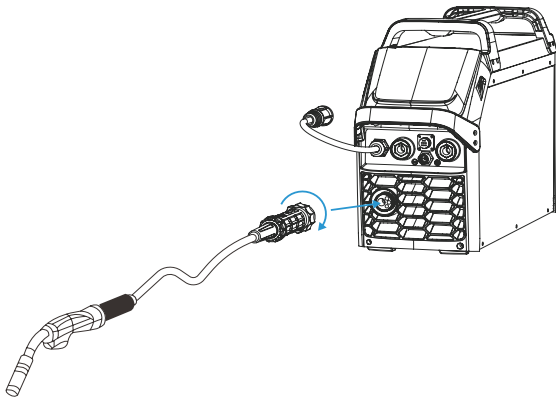

Figure 5-4: Attaching the Euro MIG Gun

## 5.07 INSTALLING MIG WIRE SPOOLS

As delivered from the factory, the unit is fitted with a Wire Spool Hub which accepts 100mm and 200mm Spool diameters.

In order to fit a 100mm or 200mm spool, assemble parts in the sequence shown below in Figure 5-5.

Adjustment of the Spool Hub Retaining Nut will control the MIG Wire Spool Brake. Clockwise rotation of this nut tightens the brake. The Brake is correctly adjusted when the spool stops within 10 to 20mm (measured at the outer edge of the spool) after MIG Gun trigger is released. Wire should be slack without becoming dislodged from the spool.



### NOTE

This spool hub nut can be removed by unscrewing in an anticlockwise direction and locating in the appropriate position.

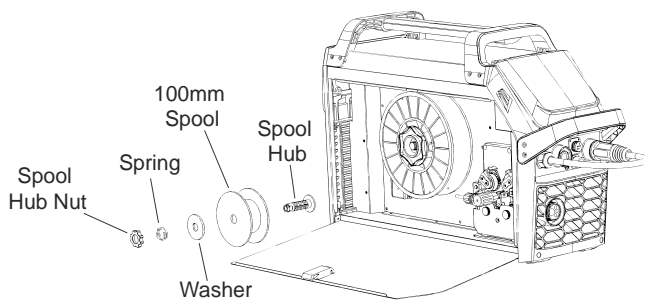

Figure 5-5: 100mm Spool Installation

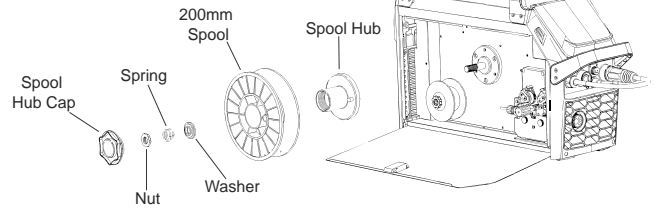

Figure 5-6: 200mm Spool Installation

## 5.08 CHANGING INLET GUIDE FOR ALUMINIUM AND SOFT WIRES

A spare Nylon Inlet Guide is supplied with the machine. It is recommended to use this with Aluminium and Other Soft Wires.

Before changing the Inlet Guide ensure wire is removed from the MIG Gun and Wire Drive system and Wire Spool is removed from the Spool Hub.

- A. Loosen Inlet Guide retaining screw as shown.

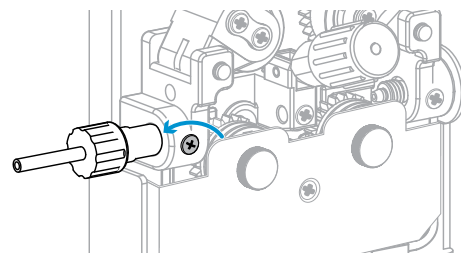

- B. Remove the Steel Inlet Guide as fitted to the machine from factory from the Wire Drive Assembly.

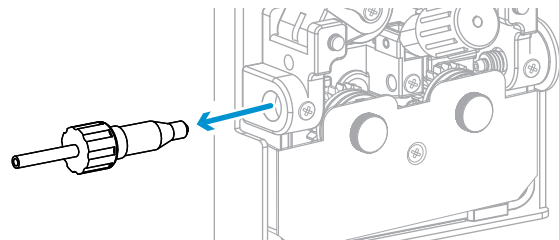

- C. Fit the Aluminium Inlet Guide into the Wire Drive Assembly as shown and tighten the retaining screw.

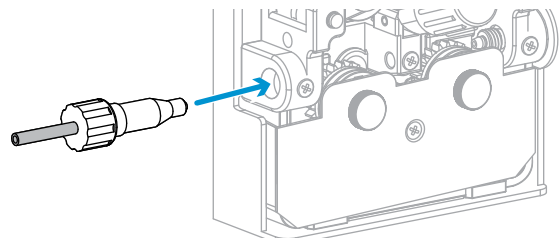

- D. Fit the appropriate feed roll to suit Aluminium wire being used. Refer to sections 5.12 Changing Feed Roll and section 2.11 Optional Accessories.
- E. Install the wire spool and carefully feed the Aluminium wire into the feed mechanism. Refer to sections 5.07, 5.09 and 5.10 for further information. A replacement Inlet Guide is available. Refer to section 2.11 Optional Accessories.

## 5.09 SPOOL HUB BRAKE

When fitting the Wire Spool, the adjustment of the nut will control the MIG Wire Spool Brake. Rotating the nut clockwise increases the brake and rotating the nut counterclockwise reduces the brake. To access the nut remove the Spool Hub Wire Spool retaining Cap. Brake is correctly adjusted when the spool stops within 10 to 20mm (measured at the outer edge of the spool) after MIG Gun trigger is released. Wire should be slack without becoming dislodged from the spool.



### WARNING

Moving Parts can cause injury!



### WARNING

Overtension of brake will cause rapid wear of mechanical WIREFEED parts, overheating of electrical componentry and possibly an increased incidence of electrode wire Burnback into contact tip.

Wire Reel Brake  
Adjustment Nut

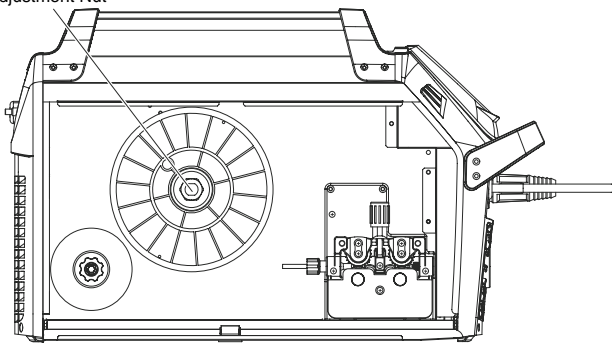

Figure 5-7: Wire Reel Brake

## 5.10 INSERTING WIRE INTO THE WIRE FEED MECHANISM

Release the tension from the pressure roller by turning the adjustable wire drive tension screw in an anticlockwise direction (Refer to Section 5.11). Then to release the pressure roller arm, pull the wire drive tension screw outward to release the pressure roller arm (Figure 5-8). With the MIG welding wire feeding from the bottom of the spool (Figure 5-9) pass the wire through the inlet guide, between the rollers, through the outlet guide and into the MIG Gun. Do not release the MIG wire until the Pressure Arm is secured back into place. Adjust the wire drive tension screw accordingly. Remove the contact tip from the MIG Gun. With the MIG Gun lead reasonably straight, feed the wire through the Gun by pressing the Wire Inch button on the control panel, or by depressing the trigger switch. Fit the appropriate contact tip.



### WARNING

Keep hands clear of the contact tip holder while feeding wire through to the gun. The wire can easily pierce your skin resulting in injury.

Keep MIG Gun away from eyes and face.



### NOTE

A spare Nylon Inlet Guide is supplied with the machine. Use this with Aluminium and other Soft Wires.

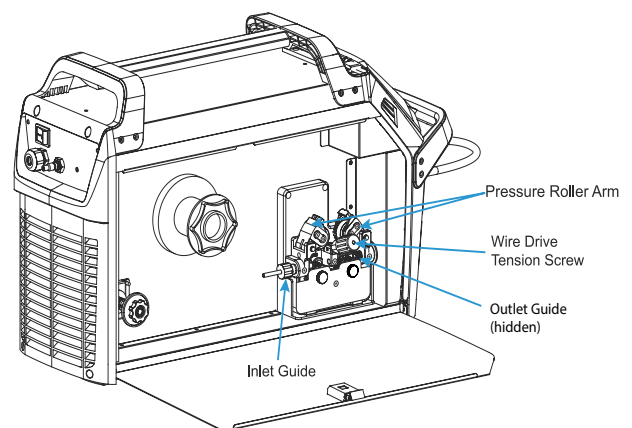

Figure 5-8: Wire Drive Assembly Components

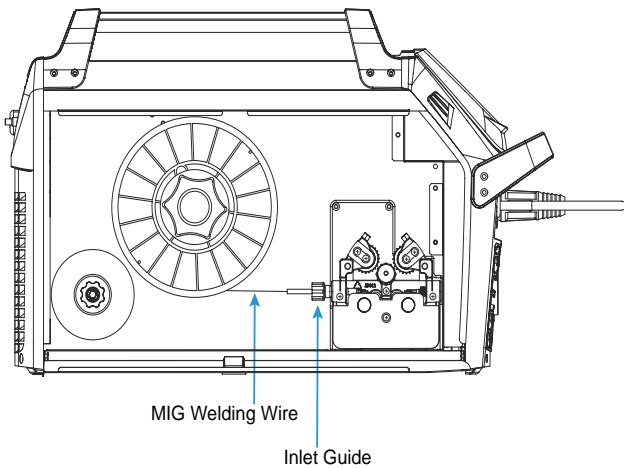

Figure 5-9 Feed Roll Insertion

## 5.11 FEED ROLL PRESSURE ADJUSTMENT

The pressure (top) rollers apply pressure to the grooved feed roll via an adjustable pressure screw. These devices should be adjusted to a minimum pressure that will provide satisfactory Wire feeding without slippage. If slipping occurs, and inspection of the wire contact tip reveals no wear, distortion or burn back jam, the conduit liner should be checked for kinks and clogging by metal flakes and swarf. If it is not the cause of slipping, the feed roll pressure can be increased by rotating the pressure screw clockwise.

A simple check for the correct drive tension is to bend the end over of the wire (once out the end of the MIG Gun) and hold it about 50mm from a piece of wood (an insulated object) and let it run into the wood. The wire should coil up without stopping and slipping at the drive rollers, tighten the pressure/tension adjustment screw if it slips.

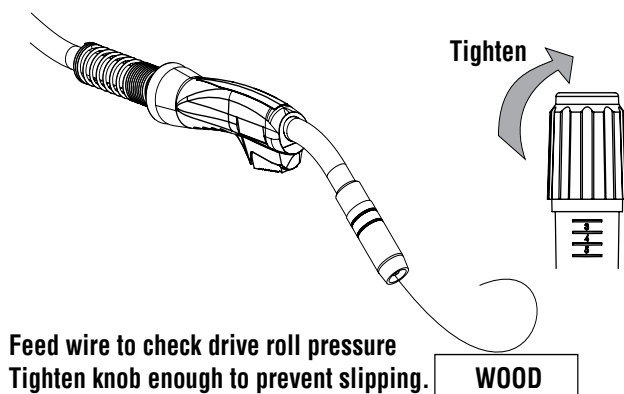

Figure 5-10: Feed Roll Pressure Adjustment

## WARNING



Keep hands clear of the contact tip holder while feeding wire through to the gun. The wire can easily pierce you skin resulting in injury.

Keep MIG Gun away from eyes and face.

## WARNING



Before changing the feed roll ensure that the mains supply to the power source is switched off.

## CAUTION



The use of excessive pressure may cause rapid wear of the feed rolls, shafts and bearing.

## 5.12 CHANGING THE FEED ROLLS

To change the feed rolls, release the Wire Drive Tension Screw and lift the Pressure Roller Arm (top roller) up and out of the way. Remove the thumb screws by turning in an anticlockwise direction, then remove the guard plate and spacers to remove the feed rolls.

When replacing the feed rolls, ensure you have the correct groove size matching the wire size you are using in the the welder. Ensure the wire size required is the number facing outward on the feed roll when feed roll is installed. Reinstall by following these instructions in reverse.

A dual K groove feed roll is fitted as standard. It can accommodate 0.8/0.9mm (Gasless Flux Cored Wires). Markings are indicated on the side edge of the feed roll, for example 0.8V, 0.9V.

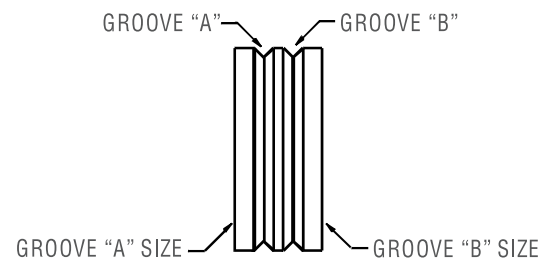

Figure 5-11: Dual Groove Feed Roll

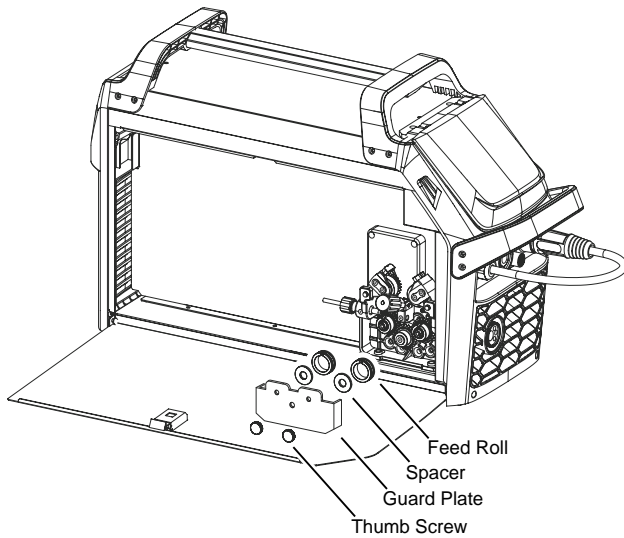

Figure 5-12: Changing the Feed Rolls



**WARNING**

Moving Parts can cause injury!

**5.13 MIG GUN POLARITY LEAD**

**Changing MIG Gun Polarity in MIG Mode.**



The MIG Gun Polarity Lead is located on the front of the machine. It can be connected to either of the Positive (+) or Negative (-) Output Terminals by inserting the twist connector into the appropriate panel socket, tightening it clockwise.

These terminals determine the polarity of the MIG Gun and the Work Lead connection.

**MIG Gun Polarity Lead Connection for Solid MIG Wire with Shielding Gas.**

1. The MIG Gun Polarity Lead must be connected to the Positive (+) Terminal on the front of the power source. This makes the MIG Gun electrode positive, which supplies 2/3 heat to the welding wire and weld deposit. Polarity electrode/wire Positive (+)

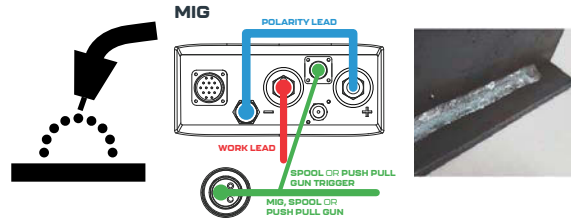

2. The Work Return cable and clamp must be connected to the negative (-) terminal by inserting the twist connector into the front panel socket and then tighten it clockwise. Connect the clamp to the work piece.

**MIG Gun Polarity Lead Connection for Gasless Flux Cored MIG Wire.**

1. The MIG Gun Polarity Lead must be connected to the Negative (-) Terminal on the front of the Power Source as shown. This makes the MIG Gun electrode negative, which supplies 1/3 heat to the welding wire and weld deposit. Polarity electrode/wire Negative (-)

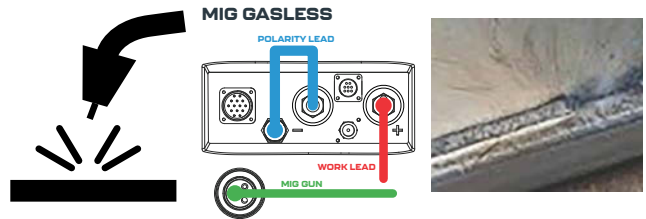

2. The Work Return cable and clamp must be connected to the positive (+) terminal by inserting the twist connector into the front panel socket and then tighten it clockwise. Connect the clamp to the work piece.

**5.14 GAS MIG (GMAW) SOLID WIRE SETUP**

- A. Ensure that the Power Source On/Off switch located on the rear of the Power Source is in the Off position.
- B. Fit the MIG Gun to the Power Source. (Refer to section 5.06 Attaching the MIG Gun).
- C. Connect the MIG Gun Polarity to the positive welding terminal (+). If in doubt, consult the wire manufacturer. Welding current flows from the Power Source via DINSE terminals. It is essential, that the male DINSE plug is inserted and turned securely to achieve a sound electrical connection.

- D. Fit the correct Feed Roll for the Gas Shielded MIG wire being used. Refer to section 2.11 Options and Accessories for Feed Roll types and Part Numbers.
- E. Place the MIG wire spool onto the spool holder. Refer to sections 5.07 for 100/200mm diameter spools.
- F. Switch the Power Source On/Off switch located on the rear of the Power Source to the On position and ensure the Front Display is illuminated.
- G. Select a MIG mode and set the corresponding Mode Parameter settings. Refer to Section 5.01 for details.
- H. Feed wire through the wire drive mechanism. Refer to section 5.10.
- I. Connect the work lead to the negative welding terminal (-). If in doubt, consult the wire manufacturer. Welding current flows from the Power Source via DINSE terminals. It is essential, that the male plug is inserted and turned securely to achieve a sound electrical connection.
- J. Fit the welding grade shielding Gas Regulator/Flowmeter to the shielding gas cylinder. Ensure that the shielding gas hose connection is sufficiently tight at the regulator connection. Refer to section 5.05 for the connection and instruction of shielding Gas Regulator/Flowmeter.



### NOTE

Power Source settings are adjusted using the front panel controls. Refer to section 5.01.



### WARNING

Before connecting the work clamp to the work piece make sure the mains power supply is switched off.



### CAUTION

Loose welding terminal connections can cause overheating and result in the male plug being fused in the terminal. Remove any packaging material prior to use. Do not block the air vents at the front or rear of the Welding Power Source.

## MIG

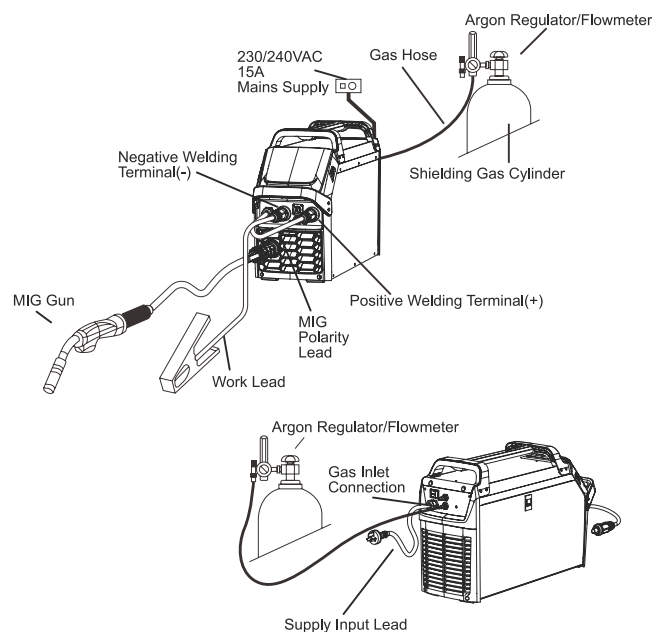
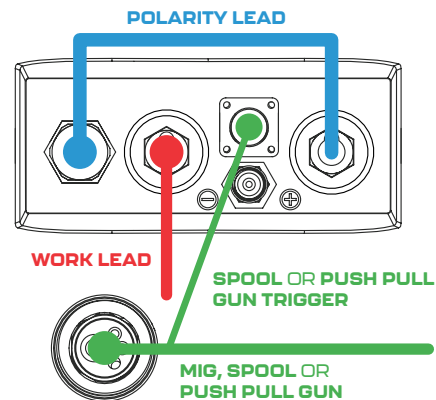

Figure 5-13: Setup for MIG Welding with Gas Shielded MIG Wire

## 5.15 GASLESS MIG (FCAW) WELDING WITH FLUXCORED WIRE

- A. Ensure that the Power Source On/Off switch located on the rear of the Power Source is in the Off position.
- B. Fit the MIG Gun to the Power Source. (Refer to section 5.06 Attaching the MIG Gun).
- C. Connect the MIG Gun Polarity to the negative welding terminal (-). If in doubt, consult the wire manufacturer. Welding current flows from the Power Source via DINSE terminals. It is essential, that the male DINSE plug is inserted and turned securely to achieve a sound electrical connection.
- D. Fit the correct Feed Roll for the Gasless MIG wire being used. Refer to section 2.11 Options and Accessories for Feed Roll types and Part Numbers.
- E. Place the MIG wire spool onto the spool holder. Refer to sections 5.07 for 100/200mm diameter spools.
- F. Switch the Power Source On/Off switch located on the rear of the Power Source to the On position and ensure the Front Panel Display is illuminated.
- G. Select MIG Synergic mode and set the corresponding Mode Parameter settings. Refer to Section 5.01 for details.
- H. Feed wire through the wire drive mechanism. Refer to section 5.10.
- I. Connect the work lead to the positive welding terminal (+). If in doubt, consult the wire manufacturer. Welding current flows from the Power Source via DINSE terminals. It is essential, that the male plug is inserted and turned securely to achieve a sound electrical connection.



### WARNING

Moving Parts can cause injury!



### WARNING

Before connecting the work clamp to the work piece make sure the mains power supply is switched off.



### CAUTION

Loose welding terminal connections can cause overheating and result in the male plug being fused in the terminal.

Remove any packaging material prior to use. Do not block the air vents at the front or rear of the Welding Power Source.



### NOTE

Synergic wire sizes for MIG GASLESS (Flux Cored Wire) are 0.8mm, 0.9mm and 1.2mm diameter.

### MIG GASLESS

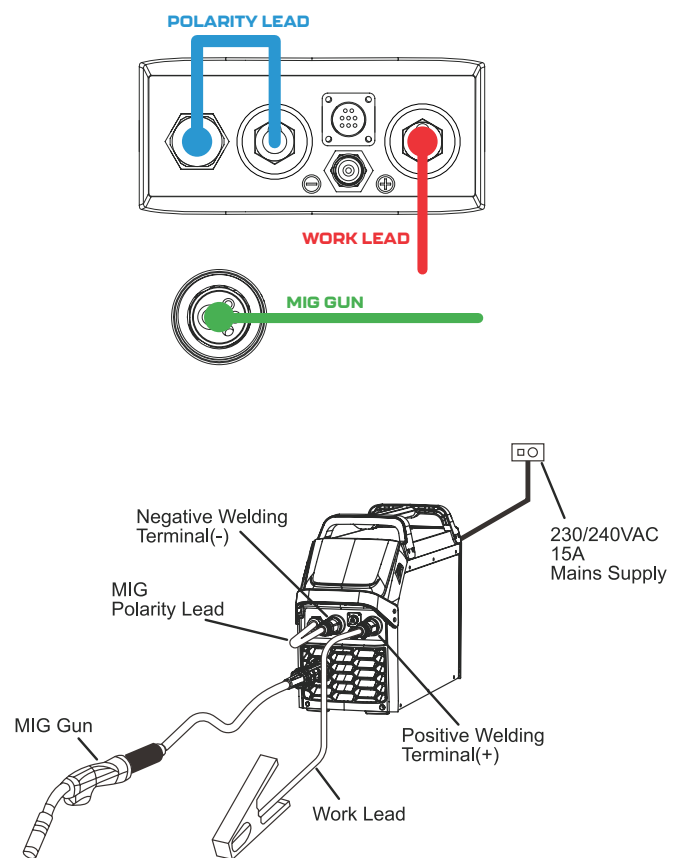

Figure 5-14: Setup for MIG Welding with Gasless MIG Wire

## 5.16 SPOOL GUN SETUP

### Spool Gun Mode Setup

The BlueVenom SiC range can run a Spool Gun in MIG Manual, Synergic and Pulse welding modes.

Using a Spool Gun not only allows you to have a longer distance between the power source and the job you are welding, with the shorter distance between the MIG wire spool and contact tip, there will be smoother wire feed speeds leading to less feedability issues. A Spool Gun is perfect for those occasions when you need the 6m long power cable to get to those hard-to-reach places and jobs that require softer wires such as 4043 aluminium.

Once MIG Manual or MIG Synergic mode is selected, another drop down menu will appear allowing the operator to select the use of a Spool Gun.



Figure 5-15: MIG Spool Gun Setup

### Spool Gun Setup

- Ensure that the Power Source On/Off switch located on the rear of the Power Source is in the Off position.
- Fit the Euro Spool Gun to the Power Source using the front panel EURO torch adaptor (refer also to section 5.06 Attaching the MIG Gun). Connect the 8 pin Remote Control Plug to the 8 pin Remote Control Socket on the power source. Ensure 8 pin plug is correctly fitted to the 8 pin socket on front panel and collar on plug is tightened firmly.
- Connect the MIG Gun Polarity to the positive welding terminal (+). If in doubt, consult the wire manufacturer. Welding current flows from the Power Source via DINSE terminals. It is essential, that the male DINSE plug is inserted and turned securely to achieve a sound electrical connection.
- Fit the correct Feed Roll in Spool Gun for the Gas Shielded MIG wire being used.
- Switch the Power Source On/Off switch located on the rear of the Power Source to the On position and ensure Front Panel is illuminated.

- Select the desired MIG mode, then select Spool Gun. Refer to Section 5.01 for further information.
- Feed wire through the wire drive mechanism in the Spool Gun.
- Connect the work lead to the negative welding terminal (-). If in doubt, consult the wire manufacturer. Welding current flows from the Power Source via DINSE terminals. It is essential, that the male plug is inserted and turned securely to achieve a sound electrical connection.
- Fit the welding grade shielding Gas Regulator/ Flowmeter to the shielding gas cylinder. Ensure that the shielding gas hose connection is sufficiently tight at the regulator connection. Refer to section 5.05 for the connection and instruction of shielding Gas Regulator/Flowmeter.



### WARNING

Before connecting the work clamp to the workpiece make sure the mains power supply is switched off.



### CAUTION

Loose welding terminal connections can cause overheating and result in the male plug being fused in the terminal. Remove any packaging material prior to use. Do not block the air vents at the front or rear of the Welding Power Source.

### MIG

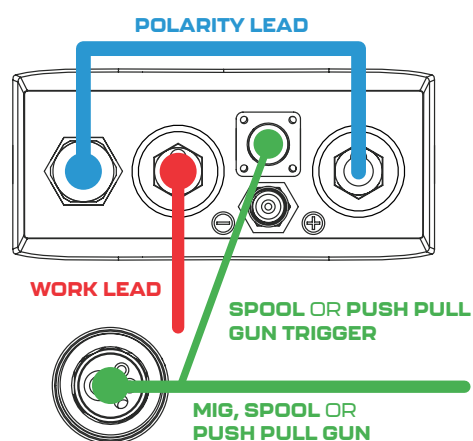

**NOTE**

If Spool gun is required to Weld using Gasless MIG Wire, the appropriate feed Roll is required, and polarity reversal. Refer to section 5.13 for setup.

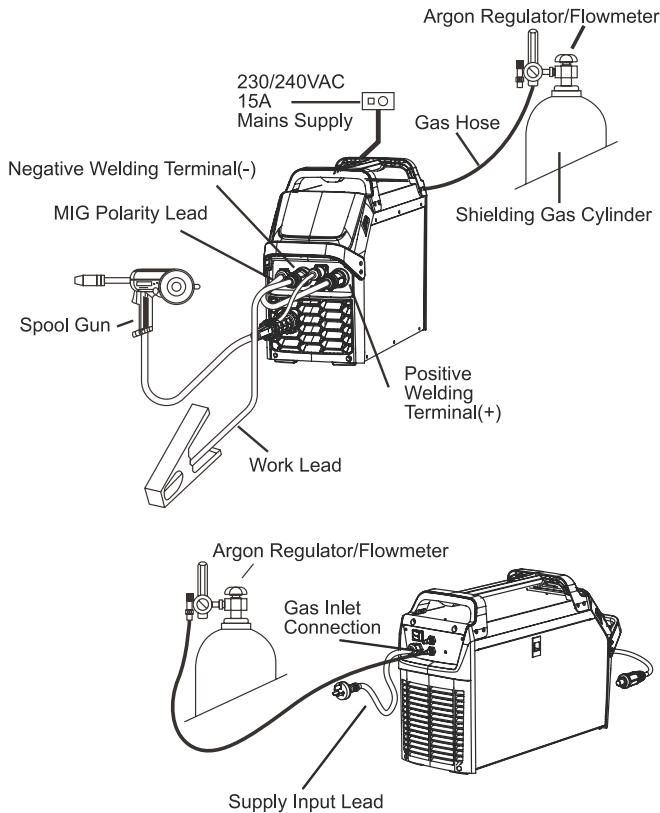

**Figure 5-16: Setup with Spool Gun for Gas Shielded MIG Wire**

## 5.17 PUSH PULL GUN SETUP

### Push Pull Gun Setup

The BlueVenom SiC range can run a Push Pull Gun in in all MIG welding modes.

Using a Push Pull Gun, much like a Spool Gun, allows for longer distances from the power source to the weld site and improves feedability when using soft wires like 4043 aluminium. A Push Pull Gun improves upon a Spool Gun with its light weight portability, since the spool isn't attached to the gun and allows for full sized spools, great for long welds in heavy duty fabrication.

Once a MIG welding mode is selected, another drop down menu will appear allowing the operator to select the use of a Push Pull Gun.



**Figure 5-17: MIG Push Pull Gun Mode**

### Push Pull Gun Setup

- Ensure that the Power Source On/Off switch located on the rear of the Power Source is in the Off position.
- Fit the Euro Push Pull Gun to the Power Source using the front panel EURO torch adaptor (refer also to section 5.06 Attaching the MIG Gun). Connect the 8 pin Remote Control Plug to the 8 pin Remote Control Socket on the power source. Ensure 8 pin plug is correctly fitted to the 8 pin socket on front panel and collar on plug is tightened firmly.
- Connect the MIG Gun Polarity to the positive welding terminal (+). If in doubt, consult the wire manufacturer. Welding current flows from the Power Source via DINSE terminals. It is essential, that the male DINSE plug is inserted and turned securely to achieve a sound electrical connection.
- Switch the Power Source On/Off switch located on the rear of the Power Source to the On position and ensure Front Panel is illuminated.
- Select the desired MIG mode, then select Push Pull Gun. Refer to Section 5.01 for further information.
- Feed wire through the wire drive mechanism of the welder though to the wire drive mechanism of the Push Pool Gun.
- Connect the work lead to the negative welding terminal (-). If in doubt, consult the wire manufacturer. Welding current flows from the Power Source via DINSE terminals. It is essential, that the male plug is inserted and turned securely to achieve a sound electrical connection.
- Fit the welding grade shielding Gas Regulator/Flowmeter to the shielding gas cylinder. Ensure that the shielding gas hose connection is sufficiently tight at the regulator connection. Refer to section 5.05 for the connection and instruction of shielding Gas Regulator/Flowmeter.

**WARNING**

Before connecting the work clamp to the workpiece make sure the mains power supply is switched off.

**CAUTION**

Loose welding terminal connections can cause overheating and result in the male plug being fused in the terminal. Remove any packaging material prior to use. Do not block the air vents at the front or rear of the Welding Power Source.

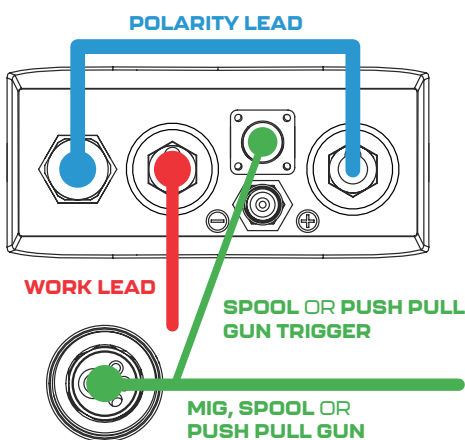
**MIG****NOTE**

If Push Pull gun is required to Weld using Gasless MIG Wire, the appropriate feed Roll is required, and polarity reversal. Refer to section 5.13 for setup.

**5.18 MIG WELDING**

Power source setting requires some practice by the operator, (however with MIG Synergic mode, setting up the correct parameters is a very simple procedure - refer to Section 5.02), as the welding plant has two control settings that have to balance. These are the Wire Feed Speed control and the welding Voltage Control. The welding current is determined by the Wire Feed Speed control, the current will increase with increased Wire Feed Speed, resulting in a shorter arc. Less Wire Feed Speed will reduce the current and lengthen the arc. Increasing the welding voltage hardly alters the current level, but lengthens the arc. By decreasing the voltage, a shorter arc is obtained with a little change in current level.

When changing to a different MIG wire diameter, different control settings are required. A thinner electrode wire needs more Wire Feed Speed to achieve the same current level.

A satisfactory weld cannot be obtained if the Wire Feed Speed and Voltage settings are not adjusted to suit the MIG wire diameter and the thickness of the work piece.

If the Wire Feed Speed is too high for the welding voltage, “stubbing” will occur as the wire dips into the molten pool and does not melt. Welding in these conditions normally produces a poor weld due to lack of fusion. If, however, the welding voltage is too high, large drops will form on the end of the wire, causing spatter. The correct setting of voltage and Wire Feed Speed can be seen in the shape of the weld deposit and heard by a smooth regular arc sound.

**MIG WIRE SIZE SELECTION**

The choice of MIG wire size and shielding gas used depends on the following:

- Thickness of the metal to be welded
- Type of joint
- Capacity of the wire feed unit and Power Source
- The amount of penetration required
- The deposition rate required
- The bead profile desired
- The position of welding
- Cost of the wire

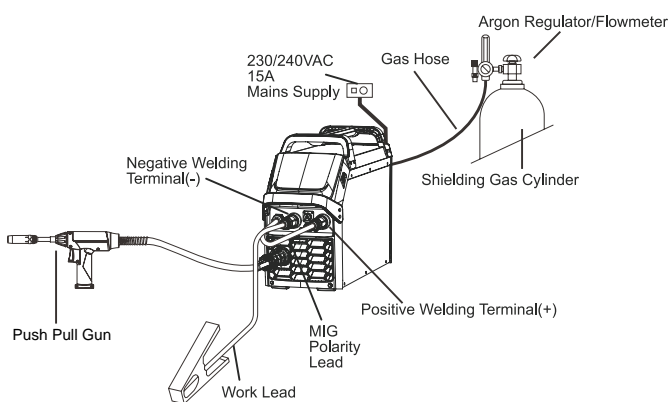

**Figure 5-18: Setup with Push Pull Gun for Gas Shielded MIG Wire**

## 5.19 CIGWELD MIG WIRE SELECTION CHART

### BLUEVENOM SiC MIG WELDING WIRE SELECTION CHART

DESCRIPTION	CLASS.	DIA.	PACK	PART NO	APPLICATION
Weldskill Solid Welding Wire	B G 49A 3U C1/M21/M24 S6 (AUS/NZ STD)  ER70S-6 (AWS STD)	0.6mm	Mini Spool 0.9kg	WS0906	General purpose solid welding wire suitable for the all positional Gas Metal Arc Welding (GWAW) of mild and low alloy steels, used in general fabrication and for welding of light to medium gauge sheet and tubular steel sections. Please Note: A suitable shielding gas is required.
		0.6mm	Handi Spool 5kg	WS5006	
		0.8mm	Mini Spool 0.9kg	WS0908	
		0.8mm	Handi Spool 5kg	WS5008	
		0.9mm	Mini Spool 0.9kg	WS0909	
		0.9mm	Handi Spool 5kg	WS5009	
Weldskill Gasless Welding Wire	B T 49 Z T11 1 NA (AUS/NZ STD)  E71T-11 (AWS STD)	0.8mm	Mini Spool 0.9kg	WG0908	WeldSkill Gasless wire is an all positional self-shielded tubular flux cored wire recommended for single and multi-pass welding applications. It is excellent for lap, fillet and butt welding of thin gauged galvanised and mild steels. The resultant welds have a full coverage easy to scrape-off thin slag covering.
		0.8mm	Handi Spool 4.5kg	WG4508	
		0.9mm	Mini Spool 0.9kg	WG0909	
		0.9mm	Handi Spool 4.5kg	WG4509	
Autocraft 316LSi Solid Stainless Steel MIG Wire	B SS316LSi (AUS/NZ STD)  ER316LSi (AWS STD)	0.8mm	Mini Spool 1kg	721285	General purpose all positional solid stainless steel wire providing excellent results when used with correct shielding gas. Suitable for the general welding of a wide range of stainless steels (300 & 400 series). Please Note: A suitable shielding gas is required.
		0.8mm	Handi Spool 5kg	720288	
		0.9mm	Handi Spool 5kg	720283	
Autocraft AL5356 Solid Aluminium MIG Wire	S Al 5356 (AUS/NZ STD)  ER5356 (AWS STD)	0.9mm	Mini Spool 0.5kg	721223	Excellent general purpose solid Aluminium MIG wire suitable for the welding of a wide range of wrought and cast Aluminium alloys containing Magnesium. Please Note: A suitable shielding gas is required.
		1.0mm	Mini Spool 0.5kg	721224	
		1.0mm	Handi Spool 2.0kg	723224	
		1.2mm	Handi Spool 2kg	720231	
Autocraft Silicon Bronze MIG Wire	ERCuSi-A (AWS STD)	0.8mm	Handi Spool 5kg	720159	A solid Silicon Bronze wire designed for MIG brazing of most metals. Used for lower strength welding of steels in automotive applications. It can also be used for welding copper-silicon alloys in hot water systems, heat exchangers and marine components. Please Note: A suitable shielding gas is required

Table 5-5: Welding Wire Selection Chart

## 5.20 MIG WELDING TROUBLESHOOTING

### SOLVING PROBLEMS BEYOND THE WELDING TERMINALS

The general approach to fix Gas Metal Arc Welding (GMAW) problems is to start at the wire spool then work through to the MIG Gun. There are two main areas where problems occur with GMAW, Porosity and Inconsistent wire feed.

### SOLVING PROBLEMS BEYOND THE WELDING TERMINALS - POROSITY

When there is a gas problem the result is usually porosity within the weld metal. Porosity always stems from some contaminant within the molten weld pool which is in the process of escaping during solidification of the molten metal. Contaminants range from no gas around the welding arc to dirt on the work piece surface. Porosity can be reduced by checking the following points.

FAULT	CAUSE
1 Shielding gas cylinder contents and flow meter.	<p><b>A</b> Ensure that the shielding gas cylinder is not empty and the flow meter is correctly adjusted to 15 litres per minute.</p> <p><b>B</b> Ensure Shielding Gas hose is connected to the MIG gas Inlet quick connect.</p>
2 Gas leaks.	Check for gas leaks between the regulator/cylinder connection and in the gas hose to the Power Source.
FAULT	CAUSE
3 Internal gas hose in the Power Source.	Ensure the hose from the solenoid valve to the gun adaptor has not fractured and that it is connected to the gun adaptor.
4 Welding in a windy environment.	Shield the weld area from the wind or increase the gas flow.
5 Welding dirty, oily, painted, oxidised or greasy plate.	Clean contaminates off the work piece.
6 Distance between the MIG Gun nozzle and the work piece.	Keep the distance between the MIG Gun nozzle and the work piece to a minimum. Refer to <a href="http://cigweld.com.au">cigweld.com.au</a> for further MIG (GMAW/FCAW) Welding information.
7 Maintain the MIG Gun in good working order.	<p><b>A</b> Ensure that the gas holes are not blocked and gas is exiting out of the gas diffuser.</p> <p><b>B</b> Do not restrict gas flow by allowing spatter to build up inside the gun nozzle.</p> <p><b>C</b> Check that the MIG Gun O-rings are not damaged.</p>

Table 5-6: Welding Terminals- Porosity



#### WARNING

Disengage the feed roll when testing for gas flow by ear.

Refer to [cigweld.com.au](http://cigweld.com.au) for further MIG (GMAW/FCAW) Welding information.

## SOLVING PROBLEMS BEYOND THE WELDING TERMINALS - INCONSISTENT WIRE FEED

Wire feeding problems can be reduced by checking the following points:

FAULT	CAUSE
<b>1</b> Feed roll driven by motor in the wirefeed compartment slipping.	<b>A</b> Spool Hub Brake is too tight. (Refer 5.09). <b>B</b> Incorrect feed roll fitted for wire used, or incorrect pressure set on wire feed pressure roller. Check and change to correct feed roll if necessary. (Refer options and accessories table 2.11 for feed roll options) Spool Hub Brake is too loose. (Refer 5.09)
<b>2</b> Wire spool unwound and tangled.	Spool Hub Brake is too loose. (Refer 5.09)
<b>3</b> Worn or incorrect feed roll size.	<b>A</b> Use a feed roll matched to the size wire you are using. <b>B</b> Replace feed roll if worn.
<b>4</b> Wire rubbed against the misaligned guides and reduced wire feedability.	Misalignment of inlet/outlet guides.
<b>5</b> Liner blocked with swarf.	<b>A</b> Increased amounts of swarf are produced by the wire passing through the feed roll when excessive pressure is applied to the pressure roller adjuster. <b>B</b> Swarf can also be produced by the wire passing through an incorrect feed roll groove shape or size. <b>C</b> Swarf is fed into the conduit liner where it accumulates thus reducing wire feedability.
<b>6</b> Incorrect or worn contact tip.	<b>A</b> The contact tip transfers the weld current to the electrode wire. If the hole in the contact tip is too large then arcing may occur inside the contact tip resulting in the wire jamming in the contact tip. <b>B</b> When using soft wire such as aluminium it may become jammed in the contact tip due to expansion of the wire when heated. A contact tip designed for soft wires should be used.
FAULT	CAUSE
<b>7</b> Poor work lead contact to work piece.	If the work lead has a poor electrical contact to the work piece then the connection point will heat up and result in a reduction of power at the arc.
<b>8</b> Bent liner.	This will cause friction between the wire and the liner thus reducing wire feedability.

Table 5-7: Inconsistent Wire Feed

## BASIC MIG (GMAW) WELDING TROUBLESHOOTING

FAULT	CAUSE	REMEDY
1 Undercut.	<p><b>A</b> Welding arc voltage too high.</p> <p><b>B</b> Incorrect gun angle.</p> <p><b>C</b> Excessive heat input.</p>	<p><b>A</b> Decrease voltage or increase the Wire Feed Speed.</p> <p><b>B</b> Adjust angle.</p> <p><b>C</b> Increase the gun travel speed and/or decrease welding current by decreasing the voltage or decreasing the Wire Feed Speed.</p>
2 Lack of penetration.	<p><b>A</b> Welding current too low.</p> <p><b>B</b> Joint preparation too narrow or gap too tight.</p> <p><b>C</b> Incorrect shielding gas.</p>	<p><b>A</b> Increase welding current by increasing Wire Feed Speed and increasing voltage.</p> <p><b>B</b> Increase joint angle or gap.</p> <p><b>C</b> Change to a gas which gives higher penetration.</p>
3 Lack of fusion.	Voltage too low.	Increase voltage.
4 Excessive spatter.	<p><b>A</b> Voltage too high.</p> <p><b>B</b> Voltage too low.</p>	<p><b>A</b> Decrease voltage or increase the Wire Feed Speed control.</p> <p><b>B</b> Increase the voltage or decrease Wire Feed Speed.</p>
5 Irregular weld shape.	<p><b>A</b> Incorrect voltage and current settings. Convex, voltage too low. Concave, voltage too high.</p> <p><b>B</b> Wire is wandering.</p> <p><b>C</b> Incorrect shielding gas.</p> <p><b>D</b> Insufficient or excessive heat input.</p>	<p><b>A</b> Adjust voltage and current by adjusting the voltage control and the Wire Feed Speed control.</p> <p><b>B</b> Replace contact tip.</p> <p><b>C</b> Check shielding gas.</p> <p><b>D</b> Adjust the Wire Feed Speed control or the voltage control.</p>
6 Weld cracking.	<p><b>A</b> Weld beads too small.</p> <p><b>B</b> Weld penetration narrow and deep.</p> <p><b>C</b> Excessive weld stresses.</p> <p><b>D</b> Excessive voltage.</p> <p><b>E</b> Cooling rate too fast.</p>	<p><b>A</b> Decrease travel speed.</p> <p><b>B</b> Reduce current and voltage and increase MIG Gun travel speed or select a lower penetration shielding gas.</p> <p><b>C</b> Increase weld metal strength or revise design.</p> <p><b>D</b> Decrease voltage.</p> <p><b>E</b> Slow the cooling rate by preheating part to be welded or cool slowly.</p>
7 Cold weld puddle.	<p><b>A</b> Loose welding cable connection.</p> <p><b>B</b> Low primary voltage.</p> <p><b>C</b> Fault in power source.</p>	<p><b>A</b> Check all welding cable connections.</p> <p><b>B</b> Contact supply authority.</p> <p><b>C</b> Have an Accredited CIGWELD Service Provider to test then replace the faulty component.</p>
8 Arc does not have a crisp sound that short arc exhibits when the Wire Feed Speed and voltage are adjusted correctly.	The MIG Gun has been connected to the wrong voltage polarity on the front panel.	Connect the MIG Gun to the positive (+) welding terminal for most solid wires and gas shielded flux cored wires. Connect MIG Gun to the negative (-) welding terminal for most Gasless Wires. Refer to the electrode wire manufacturer for the correct polarity.

Table 5-8: Welding Troubleshooting

## 5.21 MIG WELDING PROBLEMS

PROBLEM	CAUSE	REMEDY
<b>1</b> Mains Supply Voltage is On, the On/Off switch on the rear panel is in the On position and the Front Control Panel Digital Displays are illuminated however the power source will not MIG weld.	<b>A</b> Power source is not in the correct mode of operation.	<b>A</b> Set the power source to MIG mode. Refer to Section 5.16.
	<b>B</b> MIG Gun Polarity is not connected.	<b>B</b> Connect the MIG Gun Polarity to the positive or negative output terminal. Refer to Section 4.02.
	<b>C</b> Work Lead is not connected to the work piece.	<b>C</b> Ensure that the Work Lead is connected to the work piece and has a good connection to the work piece. Refer to Set Up for MIG Section 5.15 or 5.16.
	<b>D</b> MIG Gun is not correctly connected to the Euro Style MIG Gun Adaptor.	<b>D</b> Ensure that the MIG Gun is correctly connected to the Euro Style MIG Gun Adaptor. Refer to Section 4.02 & 5.06.
<b>2</b> When welding at maximum output (WFS and Volts) the machine stops welding.	<b>A</b> When output amperage exceeds the rated maximum output of the machine by 15%, the welding machine will sense this and initiates a safety circuit which stops the output current and displays an Over Current Warning Screen. Refer to Section 8.06 Warning Screens for further detail.	<b>A</b> Reduce output amperage (WFS and Volts).
	<b>B</b> Contact Tip of the MIG gun is too close to the work piece.	<b>B</b> Increase distance between the Contact Tip of the MIG gun and the work piece.
	<b>C</b> The Pre-set voltage is too high.	<b>C</b> Decrease the Pre-set voltage.
	<b>D</b> The MIG Welding Wire in use is not consistent with the selected MIG wire diameter, e.g. 0.8mm wire is selected but 0.9mm wire is used.	<b>D</b> Ensure that the correct MIG Welding Wire Diameter is selected for MIG Wire being used. Refer to Section 5.16
<b>3</b> Mains Supply Voltage is On, the On/Off switch in the rear panel is in the On position but the Front Control Panel is not illuminated and the power source will not weld.	This may occur due to the activation of an in-built protective device if the Power Source is repeatedly switched On then Off rapidly or the supply to the Power Source is switched On then Off rapidly.	If this occurs leave the Power Source On/Off switch in the Off position for several minutes to allow the protective device to reset.
<b>4</b> The power source will not commence welding when the gun trigger switch is depressed and Over Temperature Warning Screen is showing on the Front Panel Display. This indicates an Over Temperature condition has occurred. Refer to Section 8.06 Warning Screens for further detail.	Duty cycle of power source has been exceeded.	Leave the power source switched ON and allow it to cool. Note that Over Temperature Warning Screen must be cleared from the Front Panel Display prior to commencement of welding.

PROBLEM	CAUSE	REMEDY
<b>5</b> Unit will not feed wire in MIG mode.	<b>A</b> Incorrect Feed Roll fitted for wire type being used.	<b>A</b> Fit the correct feed roll for MIG wire type being used. Refer to section 2.11 for optional feed rolls available and Section 5.11 for feed roll fitting details.
	<b>B</b> Pressure Roller Arm is not secured in the correct position or not correctly adjusted.	<b>B</b> Secure Pressure Roller in the correct position and ensure that it is correctly adjusted. Refer to Section 5.11 and 5.12.
	<b>C</b> Electrode wire stuck in conduit liner or contact tip (burn-back jam).	<b>C</b> Check for clogged / kinked MIG Gun conduit liner or worn contact tip. Replace faulty components.
	<b>D</b> Internal fault in power source.	<b>D</b> Have an Accredited CIGWELD Service Provider investigate the fault.
<b>6</b> Welding wire continues to feed when MIG Gun trigger is released.	<b>A</b> MIG Gun Trigger in 4T Mode.	<b>A</b> Change MIG Gun Trigger Mode to 2T.
	<b>B</b> MIG Gun trigger leads shorted, or faulty MIG Gun Trigger.	<b>B</b> Repair or replace MIG Gun trigger switch/lead.
<b>7</b> Welding arc cannot be established in MIG mode.	<b>A</b> MIG Gun polarity lead is not connected on the welding output terminal.	<b>A</b> Connect the MIG Gun polarity to either the positive welding output terminal or the negative welding output terminal as required. Refer to Section 4.02.
	<b>B</b> Poor or no work lead contact.	<b>B</b> Clean work clamp area and ensure good electrical contact.
<b>8</b> Inconsistent wire feed.	<b>A</b> Worn or dirty contact tip.	<b>A</b> Replace if necessary.
	<b>B</b> Incorrect or worn feed roll.	<b>B</b> Replace if necessary.
	<b>C</b> Excessive brake tension on wire reel hub.	<b>C</b> Reduce brake tension on spool hub.
	<b>D</b> Worn, kinked or dirty conduit liner.	<b>D</b> Clean or replace conduit liner.
	<b>E</b> Pressure Roller Arm is not secured in the down position or not correctly adjusted.	<b>E</b> Secure Pressure Roller in the down position and ensure that it is correctly adjusted. Refer to Section 5.11 and 5.12.
<b>9</b> No gas flow in MIG mode.	<b>A</b> Gas hose is damaged.	<b>A</b> Replace or repair.
	<b>B</b> Gas passage contains impurities.	<b>B</b> Disconnect gas hose from the rear of power source and blow out impurities.
	<b>C</b> Machine set in MIG Gasless mode.	<b>C</b> Set Machine to MIG Gas mode.
	<b>D</b> Empty gas cylinder.	<b>D</b> Replace gas cylinder.
	<b>E</b> Cylinder Valve not turned on.	<b>E</b> Turn Cylinder valve in anticlockwise direction until gas is flowing.
<b>10</b> Gas flow continues after the MIG Gun trigger switch has been released (MIG Gas Solid mode).	Gas valve has jammed open due to impurities in the gas or the gas line.	Have an accredited CIGWELD service provider repair or replace gas valve.

Table 5-9: Welding Problems

# SECTION 6: TIG (GTAW) WELDING

## 6.01 TIG MODE SETUP



### 1. Menu Button

Press the Menu Button to display a drop down list of the available welding Mode Parameters. Rotate the Left Control Knob to scroll through the available options, press to confirm and move to the next parameter. Optionally, press the Menu Button to move to the next parameter without confirming a selection. After a short period, if no input is made to the Menu Button or Left Control Knob, the drop down list will disappear without confirming the highlighted option.

### 2. Mode Parameters

The Mode Parameters available depend on the TIG welding mode selected. When selecting some TIG modes a second drop down list will appear. This gives the user the option to choose the Arc Start method, HF or Lift.

Use the Left Control Knob to select an option, if no option is selected after a short period, the drop down list will disappear without confirming the highlighted option. Refer to Section 6.02 for the available TIG Mode Parameters.

### 3. Weld Parameters



The left side of the screen displays the available Control parameters. Rotate the Left Control Knob to highlight the desired parameter, then rotate the Right Control Knob to adjust. After a short duration, if no input is made the highlighted parameter will return to the default, Peak Current. Refer to Section 6.03 for the available TIG Weld Parameters.

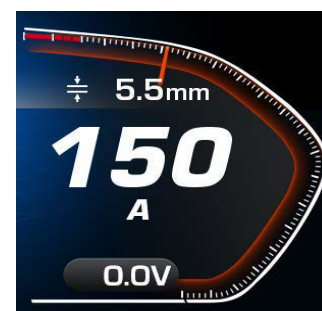

The right side of the screen displays the live output welding voltage and the value of the highlighted Weld Parameter. Rotate the Right Control Knob to adjust the Weld Parameter value. When welding, the output current will be displayed instead, overwriting the Weld Parameter value.

Additionally, TIG Synergic mode will display a Plate Thickness value. This value depends on the Peak Current and Joint Type selected, and is to be used as a guide only.

## 6.02 TIG - MODE PARAMETERS

PARAMETER	OPTIONS AVAILABLE	DESCRIPTION
TIG Mode	TIG MAN. TIG SYN. TIG MIX* TIG COLD	<p><b>TIG Manual</b> This is the standard mode found on most TIG welders. In this mode the operator has complete control over the Weld Control parameters</p>
		<p><b>TIG Synergic</b> This mode utilizes pre-installed weld settings referred to as Synergic Lines. The operator simply selects the remaining Mode Parameters, and a recommended Welding current and Plate Thickness is set.</p>
		<p><b>TIG Mixed*</b> In this mode the output current switches between an AC waveform and direct current, mixing the cleaning properties of AC TIG and penetrating power of DC TIG.</p>
		<p><b>TIG Cold Weld</b> Cold Welding uses ultra-short pulses to weld metals together. This generated less heat than traditional TIG welding, perfect for thin delicate metals.</p> <p><i>*TIG Mixed is not available on the BlueVenom XF195 SiC</i></p>
Arc Start	HF LIFT	<p><b>HF</b> High frequency start (HF) creates an arc between the torch tip and work piece using a high-voltage / low-current pulse. The high voltage ionizes the air to create plasma, allowing the main arc to initiate. To initiate an arc, simply place the torch tip above the workpiece and press the torch trigger.</p>
		<p><b>LIFT</b> Lift-arc creates an arc by pressing the torch tip to the workpiece, pressing the trigger and then lifting the torch. The welder senses the low resistance between the torch tip and the workpiece, then as the torch is lifted the resistance increases and the output current begins to flow.</p>
Remote Control	Torch Control Foot Pedal	Select the method of control used to remotely adjust the welding current. If using a Foot Pedal for remote control, the available Trigger Mode is limited to 2T.

PARAMETER	OPTIONS AVAILABLE	DESCRIPTION
Trigger		<p><b>2T</b> In this mode, the trigger must remain depressed for the welding output to be active. Release the trigger switch to cease welding.</p> <p><b>4T – Latch Mode</b> In this mode the operator can press and release the trigger begin welding. This is ideal for long weld periods to reduce strain and fatigue. Press and release the trigger again to cease welding.</p> <p>Additionally operator has control over the Pre and Post Current durations directly. When initiating the weld, the output will remain at the Pre Current as long as the trigger is held. When welding ends, the output will remain at the Post Current as long as the trigger is held. Releasing the trigger will begin the Up Slope process or stop welding respectively.</p>
	2T	
	4T	
	8T*	
	SPOT**	
	MULTI**	
		<p><b>8T*</b> This mode acts the same as 4T mode with an additional Secondary Welding Current. A short trigger press will switch the output to the Secondary parameters, continue to short press to alternate between the primary and secondary parameters. To cease welding, hold the trigger until the machine reduces the output to the End Current or stops welding.</p> <p><b>Single Spot**</b> This mode is used for Spot Welding. Press the trigger to output the Welding Current for a short interval.</p> <p><b>Multi Spot**</b> This mode is used for continuous Spot Welding. Press and hold the trigger to repeatedly Spot Weld with a short interval between each Spot Weld. Release the trigger to cease welding.</p> <p><i>*Not available in TIG Mixed and TIG Cold Weld modes.</i> <i>**Only available in HF TIG Manual mode</i></p>
Waveform*	DC	
	Sine-Square	
	Square Wave	Sine-Triangle
	Square-Sine	Triangle Wave
	Square-Triangle	Triangle-Sine
	Sine Wave	Triangle-Square
		<p>This the waveform of the output Welding Current. Select up to 9 different AC waveforms, offering greater control over the welding process. TIG Synergic mode only offers DC, square wave and sine wave.</p> <p><i>*Parameter not available on BlueVenom XF195 SiC</i></p>

PARAMETER	OPTIONS AVAILABLE	DESCRIPTION
Pulse	No Pulse	<b>Pulse</b> When enabled the output signal is pulsed between the Peak Current and Base Current. Utilizing the pulse function can improved weld quality, offering better control over the welding process, especially when working with challenging materials or in demanding welding applications.
	Pulse Super Pulse	<b>Super Pulse</b> This mode functions the same as Pulse mode, while adding a boost to the rising edge of each pulse. This helps improve low-frequency pulse performance, below 10Hz.  <i>Not available in TIG Cold Weld, Spot and Multi Spot modes</i>
Electrode Diameter	1.6mm	The Electrode Diameter parameter is used to set the Welding Current range. This ensures enough current is used to create a stable arc, but not so much as to damage the electrode.
	2.0mm	
	2.4mm	
	3.2mm	
	4.0mm	
Filler Material	SS/CS (DC)	The Filler Material parameter is used to set the Synergic Welding Current and Plate Thickness to ensure a reliable weld. The options available depend on the output waveform selected.  <i>Only available in TIG Synergic mode.</i>
	Bronze/SilBrnz (DC)	
	Al 5356 (Square Wave)	
	Al 4043 (Square Wave)	
Joint Type	Al (Sine Wave)	The Joint Type parameter is used to set the Synergic Welding Current and Plate Thickness to ensure a reliable weld.  <i>Only available in TIG Synergic mode.</i>
	Fillet Weld	
	Lap Weld	
	Butt Weld	
	Vertical Weld	

Table 6-1: TIG Mode Parameters

### 6.03 TIG - WELD PARAMETERS

PARAMETER	VALUE RANGE	DEFAULT VALUE	DESCRIPTION
Pre Gas	0.0 – 2.0s	0.0s	Pre Gas is a short burst of shielding gas prior to the arc initiating, reducing the risk of contamination at the start of the weld
Pre Current	Min – Max Current	50A	Pre Current is the output current after a weld is first initiated. This is often set higher than the Welding Current, preventing the electrode from sticking and ensuring adequate fusion while the weld plate is still cool. Refer also Section 4.05.

PARAMETER	VALUE RANGE	DEFAULT VALUE	DESCRIPTION
Up Slope	0.0 – 10.0s	0.0s	Up Slope is the time it takes to adjust the output current from the Pre Current to the Peak Current. This is used to reduce the heat stress placed on the welding plate. Refer also Section 4.05.
Peak Current	Min – Max Current	50A	Peak Current is the Welding Current, and in pulsed mode this is the higher current of the Pulse Cycle. The Peak Current in the pulse cycle generates more heat, allowing for better fusion and penetration into the base metal.
Secondary Peak Current	Min – Peak Current	Peak Current	Secondary Peak Current is the alternate Peak Current in 8T Trigger Mode. <i>Only available in 8T Trigger Mode.</i>
Base Current	Min – Peak Current	30A	Base Current is the lower current of the Pulse Cycle. It helps reduce heat buildup, minimizing the risk of distortion and burn-through. <i>Only available if pulse is enabled</i>
Secondary Base Current	Min - Base Current	Base Current	Secondary Base Current is the alternate Base Current in 8T Trigger Mode. <i>Only available in 8T Trigger Mode.</i>
Pulse Width	15 – 95%.	50%	Pulse Width is the amount of time the output current remains at the Peak Current level before returning to the Base Current level. This is measured as a percentage of the Pulse Frequency. <i>Only available if pulse is enabled.</i>
Pulse Frequency	0.5 – 999Hz	1Hz	Pulse Frequency is the number of times per second that the output current cycles between the Peak Current and Base Current. Higher frequencies result in more rapid cycling between the two current levels. <i>Only available if pulse is enabled</i>
Down Slope	0.0 – 10.0s	0.0s	Down Slope is the time it takes to reduce the Peak Current to the Post Current when welding has ended. This time is often used to fill the crater and smoothly finish the weld. Refer also Section 4.05.
Post Current	Min – Max Current	50A	Post Current is the ending output current, used to fill the weld joint and avoid creating a crater at the end of the weld. Refer also Section 4.05.

PARAMETER	VALUE RANGE	DEFAULT VALUE	DESCRIPTION
Post Gas	0.0 – 5.0s	2.0s	Post Gas continues to emit shielding gas after welding has ended, reducing the risk of contamination at the end of the weld.
AC Frequency*	50 – 250Hz	50Hz	<p>AC Frequency adjusts the frequency of the selected AC Waveform. Low frequencies below 100Hz produce a wider arc cone and more heat, suitable for thick materials. Higher frequencies above 150Hz produce a focused narrow arc, suitable for thin materials.</p> <p><i>*Only available with AC output. Not available on the BlueVenom XF195 SiC.</i></p>
Balance*	-5 – 5	0	<p>Balance is used for aluminium welding in AC TIG mode, adjusting the duty cycle of the output waveform. Increasing the value increases the AC outputs cleaning actions, whereas decreasing the value increases weld penetration.</p> <p><i>*Only available with AC output. Not available on the BlueVenom XF195 SiC.</i></p>
Electrode Negative*	Min – Max Current	Peak Current	<p>Electrode Negative allows precise control of the output current when the AC Waveform is in negative polarity. Adjusting this value will also adjust the Peak Current in response.</p> <p><i>*Only available with AC output. Not available on the BlueVenom XF195 SiC.</i></p>
Electrode Positive*	Min – Max Current	Peak Current	<p>Electrode Positive allows precise control of the output current when the AC Waveform is in positive polarity. Adjusting this value will also adjust the Peak Current in response.</p> <p><i>*Only available with AC output. Not available on the BlueVenom XF195 SiC.</i></p>
Dynamic Arc ON/OFF	On	100%	<p>Dynamic Arc permits the output current to change in response to arc voltage fluctuations. This is used to maintain consistent heat input as arc length varies.</p> <p><i>Not available if using pulse, mixed waveforms, spot welding or TIG COLD modes.</i></p>

PARAMETER	VALUE RANGE	DEFAULT VALUE	DESCRIPTION
Dynamic Arc Value	1 – 100A/V	1A/V	<p>Dynamic Arc Value permits the output current to change, per change of 1V. For example, with a Dynamic Arc Value of 20A/V if the machine senses a 1V increase to the arc voltage, the output current will reduce by 20A to compensate.</p> <p><i>Not available if using pulse, mixed waveforms, spot welding or TIG COLD modes.</i></p>
AC Time*	0.01 – 1.00s	0.10s	<p>AC Time is the amount of time the output current operates as the selected AC Waveform.</p> <p><i>*Only available in TIG Mixed mode. Not available on the BlueVenom XF195 SiC.</i></p>
DC Time*	0.01 – 1.00s	0.10s	<p>DC Time is of amount of time the output current operates as direct current.</p> <p><i>*Only available in TIG Mixed mode. Not available on the BlueVenom XF195 SiC.</i></p>
Time On	0.1 – 10s (Single Spot) 0.1 – 10s (Multi Spot) 0.1 – 10s (TIG Cold Spot)	0.1s (Spot/Multi Spot) 0.02s (TIG Cold Weld)	<p>Time On sets the duration of the welding time in Spot, Multi Spot and TIG Cold Weld modes. The maximum duration depends on the mode being used.</p> <p><i>Only available in Spot, Multi Spot and TIG Cold Weld modes.</i></p>
Time Off	0.1 – 10s	0.1s	<p>Time Off sets the duration between welds (where the machine is not welding) in Multi Spot and TIG Cold Weld modes.</p> <p><i>Only available in Multi Spot and TIG Cold Weld modes.</i></p>

Table 6-2: TIG Weld Parameters

## 6.04 TIG WELDING BASICS

Gas Tungsten Arc Welding (GTAW) or TIG (Tungsten Inert Gas) as it is commonly referred to, is a welding process in which fusion is produced by an electric arc that is established between a single tungsten (non-consumable) electrode and the work piece. Shielding is obtained from a welding grade shielding gas or welding grade shielding gas mixture which is generally Argon based. A filler metal may also be added manually in some circumstances depending on the welding application.

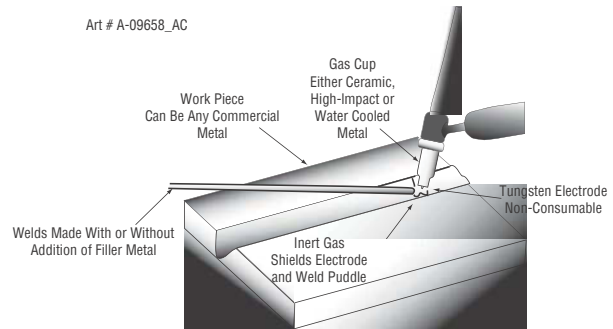

Figure 6-1: TIG Welding Application Shot

## GENERAL GUIDE FOR TIG WELDING

METAL THICKNESS	JOINT TYPE	TUNGSTEN ELECTRODE DIAMETER	FILLER ROD DIAMETER (IF REQUIRED)	AMPERAGE	ARGON GAS FLOW RATE AMPERAGE (L/MIN*)
1.0mm	Butt / Corner	1.0mm	1.6mm	30 - 45	5 - 7
	Lap / Fillet			35 - 50	
1.2mm	Butt / Corner	1.0mm	1.6mm	40 - 60	5 - 7
	Lap / Fillet			45 - 70	
1.6mm	Butt / Corner	1.6mm	1.6mm	60 - 85	7
	Lap / Fillet			70 - 95	
3.2mm	Butt / Corner	2.4mm	2.4mm	125 - 150	10
	Lap / Fillet	3.2mm		130 - 160	
5.0mm	Butt / Corner	3.2mm	3.2mm	180 - 225	10
	Lap / Fillet	4.0mm		190 - 240	
6.0mm	Butt / Corner	4.0mm	4.8mm	240 - 280	13
	Lap / Fillet	4.8mm		250 - 320	

\*Flow rates are for welding grade argon only, see manufacturers' recommendations for mixtures. Size and shape of gas nozzle has an effect on the flow required for effective gas cover.

Table 6-3: TIG Welding Guide



### NOTE

The operator should use the welding current range values as a guide only, then finally adjust the current setting to suit the application.

**CIGWELD TIG WELDING FILLER RODS SELECTION CHART**

DESCRIPTION	CLASS.	DIA.	PACK	PART NO	APPLICATION
<b>COMWELD SUPER STEEL</b>	R2 (AUS/NZ STD)	1.6mm	5kg Pack	321370	Comweld Super Steel is a copper coated 'triple deoxidised' steel welding rod recommended for the high quality Gas Tungsten Arc (TIG) welding of carbon and carbon-Manganese steels. Comweld Super Steel is deoxidised with Titanium, Aluminium and Zirconium in addition to Manganese and Silicon for improved weld deposit quality. It is the ideal choice for TIG welding rusty or mill scaled plates and pipes and the root pass welding of pipes, tanks and heavy walled root toughness and radiographic soundness are achieved under high dilution.
	ER70S-2 (AWS STD)	2.4mm	5kg Pack	321373	
<b>COMWELD LW1-6</b>	R6 (AUS/NZ STD)	1.6mm	5kg Pack	321417	Comweld LW1-6 is a copper coated, low carbon steel filler rod suitable for Gas Tungsten Arc (TIG) welding of a wide range of mild and medium strength steels. Comweld LW1-6 is recommended for the TIG welding of steel pipes, plates and castings with a tensile strength in the 500 MPa class. It is tolerant to surface rust and mill scale and is ideal for root pass welding applications where tough and ductile welds are produced. Please Note: A suitable shielding gas is required.
	ER70S-6 (AWS STD)	2.4mm	5kg Pack	321418	
<b>COMWELD 308L</b>	R308L (AUS/NZ STD)	1.6mm	5kg Pack	321406	Comweld 308L stainless steel is a high quality low carbon rod for the Gas or Gas Tungsten Arc (TIG) welding of a wide range of low carbon and stabilised 300 series stainless steels. It is recommended for the critical welding of 304 and 304L stainless steels in corrosion resistant and cryogenic applications.
	ER308L (AWS STD)	2.4mm	5kg Pack	321407	
<b>COMWELD 309L</b>	R309L (AUS/NZ STD)	1.6mm	5kg Pack	321403	Comweld 309L stainless steel is a high quality low carbon rod for the Gas or Gas Tungsten Arc (TIG) welding of highly alloyed 309 or 309L type stainless steels. Comweld 309L is also suitable for the dissimilar joining of other 300 series austenitic stainless steels to ferritic steels.
	ER309L (AWS STD)	2.4mm	5kg Pack	321404	
<b>COMWELD 316L</b>	R316L (AUS/NZ STD)	1.6mm	5kg Pack	321400	Comweld 316L stainless steel is a high quality low carbon rod for the Gas or Gas Tungsten Arc (TIG) welding of Molybdenum bearing stainless steels; in particular matching 316 and 316L alloys. Comweld 316L is also suitable for the general welding of other 300 series stainless steels including 302 and 304; as well as ferritic stainless steels grades such as 409, 444 and 3Cr12.
	ER316L (AWS STD)	2.4mm	5kg Pack	321401	

**CIGWELD TIG WELDING FILLER RODS SELECTION CHART**

DESCRIPTION	CLASS.	DIA.	PACK	PART NO	APPLICATION
COMWELD 316LSi	R316LSi (AUS/NZ STD)	1.6mm	5kg Pack	321426	Comweld 316L stainless steel is a high quality low carbon rod for the Gas or Gas Tungsten Arc (TIG) welding of Molybdenum bearing stainless steels; in particular matching 316 and 316L alloys. Comweld 316L is also suitable for the general welding of other 300 series stainless steels including 302 and 304; as well as ferritic stainless steels grades such as 409, 444 and 3Cr12.
	ER316LSi (AWS STD)	2.4mm	5kg Pack	321427	
COMWELD AL5356	R5356 (AUS/NZ STD)	1.6mm	2.5kg Pack	321640	Comweld AL5356 is a high quality, Aluminium - nominal 5% Magnesium alloy rod suitable for the Gas or Gas Tungsten Arc (TIG) welding of a wide range of cast and wrought Aluminium alloys. It produces intermediate deposit strength and good ductility and corrosion resistance for the Gas or Gas Tungsten Arc Welding (GTAW / TIG) of a wide range of 3XXX, 5XXX, 6XXX and 5XX Aluminium alloys. See CIGWELD Aluminium Alloy Selection Chart for detailed welding consumable selection criteria for a wide range of Aluminium alloy parent metals.
		2.4mm	2.5kg Pack	321641	
	ER5356 (AWS STD)	3.2mm	2.5kg Pack	321642	
COMWELD AL4043	R4043 (AUS/NZ STD)	1.6mm	2.5kg Pack	321610	Comweld AL4043 is a premium quality Aluminium - nominal 5% Silicon alloy rod used extensively for the repair welding (fractures and blow holes etc) of selected aluminium alloy castings. Its lower weld deposit strength and excellent crack resistance make it suitable for the Gas or Gas Tungsten Arc (GTAW / TIG) welding of cast (mainly 4XX & 6XX series) alloys and wrought (selected 1XXX, 5XXX & 6XXX series) aluminium alloys, except where an accurate colour match is required after anodising.
		2.4mm	2.5kg Pack	321611	
	ER4043 (AWS STD)	3.2mm	2.5kg Pack	321612	

**Table 6-4: Welding Filler Rods Selection Chart**

TIG Welding is generally regarded as a specialised process that requires operator competency. While many of the principles outlined in the previous Arc Welding section are applicable a comprehensive outline of the TIG Welding process is outside the scope of this Operating Manual. For further information please refer to [cigweld.com.au](http://cigweld.com.au) or contact **Cigweld**.

## 6.05 TIG REGULATOR/ FLOWMETER

### SHIELDING GAS CONNECTION



#### WARNING

This equipment is designed for use with welding grade (Inert) shielding gases only.

This regulator/flowmeter is designed to reduce and control high pressure gas from a cylinder or pipeline to the working pressure required for the equipment using it.

If the equipment is improperly used, hazardous conditions are created that may cause accidents. It is the users responsibility to prevent such conditions. Before handling or using the equipment, understand and comply at all times with the safe practices prescribed in this instruction.

**SPECIFIC PROCEDURES** for the use of regulators/flowmeters are listed below.

1. **NEVER** subject the Regulator/Flowmeter to an inlet pressure greater than its rated inlet pressure.
2. **NEVER** pressurize a Regulator/Flowmeter that has loose or damaged parts or is in a questionable condition. NEVER loosen a connection or attempt to remove any part of a Regulator/Flowmeter until the gas pressure has been relieved. Under pressure, gas can dangerously propel a loose part.
3. **DO NOT** remove the Regulator/Flowmeter from a cylinder without first closing the cylinder valve and releasing gas in the Regulator/Flowmeter high and low pressure chambers.
4. **TURN OFF** When equipment is not in use for extended periods of time, shut off the gas at the cylinder valve and release the gas from the equipment.
5. **OPEN** the cylinder valve **SLOWLY**. Close after use.



#### CAUTION

Match regulator/flowmeter to cylinder. NEVER CONNECT a regulator/flowmeter designed for a particular gas or gases to a cylinder containing any other gas.

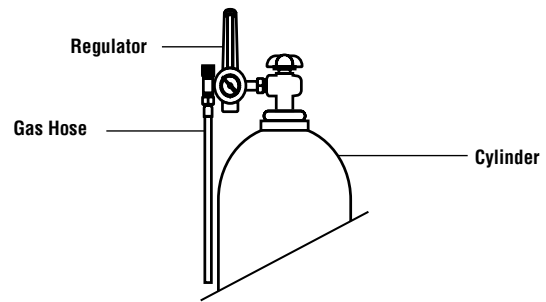

Figure 6-2: fit regulator/flowmeter to cylinder

### INSTALLATION

1. Remove cylinder valve plastic dust seal. Clean the cylinder valve outlet of impurities that may clog orifices and damage seats before connecting the Regulator/Flowmeter. Crack the valve (open then close) momentarily, pointing the outlet away from people and sources of ignition. Wipe with a clean lint free cloth.
2. Match Regulator/Flowmeter to cylinder. Before connecting, check that the Regulator/Flowmeter label and cylinder marking agree and that the Regulator/Flowmeter inlet and cylinder outlet match. NEVER CONNECT a Regulator/Flowmeter designed for a particular gas or gases to a cylinder containing any other gas.
3. Connect the Regulator/Flowmeter inlet connection to cylinder or pipeline and tighten it firmly but not excessively, with a suitable spanner.
4. Connect and tighten the outlet hose firmly and attach the hose to the welding machine with the Quick Connect fitting. Ensure no gas leakage. The flowmeter must be in the vertical position to read accurately.
5. The regulator/flowmeter has a self-reseating relief valve – not designed to protect downstream equipment. To protect sensitive downstream equipment a separate safety device may be necessary.

## OPERATION

With the Regulator/Flowmeter connected to cylinder or pipeline:

1. Stand to one side of Regulator/Flowmeter and slowly open the cylinder valve. If opened quickly, a sudden pressure surge may damage internal Regulator/Flowmeter parts.
2. Since the regulator is a preset type, no adjustments to the regulator are necessary. Before opening the cylinder valve, be sure that the flow adjusting valve is in a finger-tight "OFF" position (clockwise).
3. Slowly and carefully, open the cylinder valve until the maximum pressure registers on the high pressure gauge.



### CAUTION

DO NOT purge oxidising or flammable gases in the presence of flame, lit cigarettes, or other sources of ignition or in a confined space.

Close equipment valve(s) after purging, and test all connections for leaks with a suitable leak detection solution or soapy water.

Never use a flame when testing for leaks.

## ADJUSTING FLOW RATE

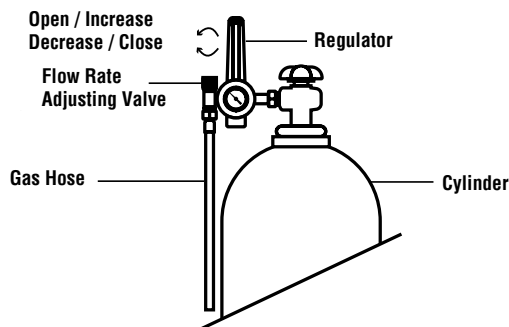

Figure 6-3: adjust flow rate

With the Regulator/Flowmeter ready for operation, adjust working flow rate as follows:

1. Slowly turn adjusting valve in anti-clockwise direction to open and increase until the bobbin in the flow tube indicates the required flow rate.

### **i** NOTE

It may be necessary to re-check the shielding Gas Regulator/Flowmeter flow rate following the first weld sequence due to back pressure present within shielding gas hose assembly.

2. To reduce flow rate, allow the welding grade shielding gas to discharge from regulator by opening the downstream valve. Bleed welding grade shielding gas into a well ventilated area and away from any ignition source. Turn adjusting screw clockwise, until the required flow rate is indicated on the gauge. Close downstream valve.

## SHUTDOWN

Close cylinder valve whenever the Regulator/Flowmeter is not in use. To shut down for extended periods (more than 30 minutes).

1. Close cylinder valve tightly.
2. Remove the gas from the machine and hose by pressing the Gas Purge button on the front of the machine, or by pressing the trigger on the MIG Gun. Bleed gas into a well ventilated area.
3. After gas is drained completely turn off the machine.
4. Before transporting cylinders that are not secured on a cart designed for such purposes, remove regulators/flowmeters.

## 6.06 TIG WELDING

- A. Select a TIG mode with the process selection control (refer to Section 6.01 for further information).
- B. Connect the TIG Torch to the negative welding terminal (-). Refer to Note below for Optional TIG Torch information. Welding current flows from the power source via Dinse type terminals. It is essential, however, that the male plug is inserted and turned securely to achieve a sound electrical connection.
- C. Connect the TIG torch trigger switch and remote current control if applicable via the 8 pin socket located on the front of the Power Source. The TIG torch will require a trigger switch to weld in TIG Mode.
- D. Connect the work lead to the positive welding terminal (+). Welding current flows from the Power Source via Dinse type terminals. It is essential, however, that the male plug is inserted and turned securely to achieve a sound electrical connection.
- E. Connect the Argon Regulator/Flowmeter to the Welding Grade Argon Shielding Gas Cylinder then connect the TIG Torch gas hose to regulator. Before turning on shielding gas check that all fittings are tight and the gas valve on the TIG torch is turned off. Before commencing to TIG weld open TIG torch gas valve to allow sufficient shielding gas flow when welding. Refer to Section 5.05 for recommended Shielding Gas flow rates and other TIG Welding information.



### WARNING

Secure the welding grade shielding gas cylinder in an upright position by chaining it to a suitable stationary support to prevent falling or tipping.

Open Gas Cylinder Valve carefully.



### WARNING

Before connecting the work clamp to the work piece and inserting the electrode in the TIG torch make sure the Mains power supply is switched off.



### CAUTION

Remove any packaging material prior to use. Do not block the air vents at the front or rear of the Welding Power Source.



### NOTE

If the TIG torch has a trigger switch or a remote TIG torch current control fitted then it will require to be connected to the 8 pin socket. (Refer to section 4.02.4 Remote Control Socket for further information).

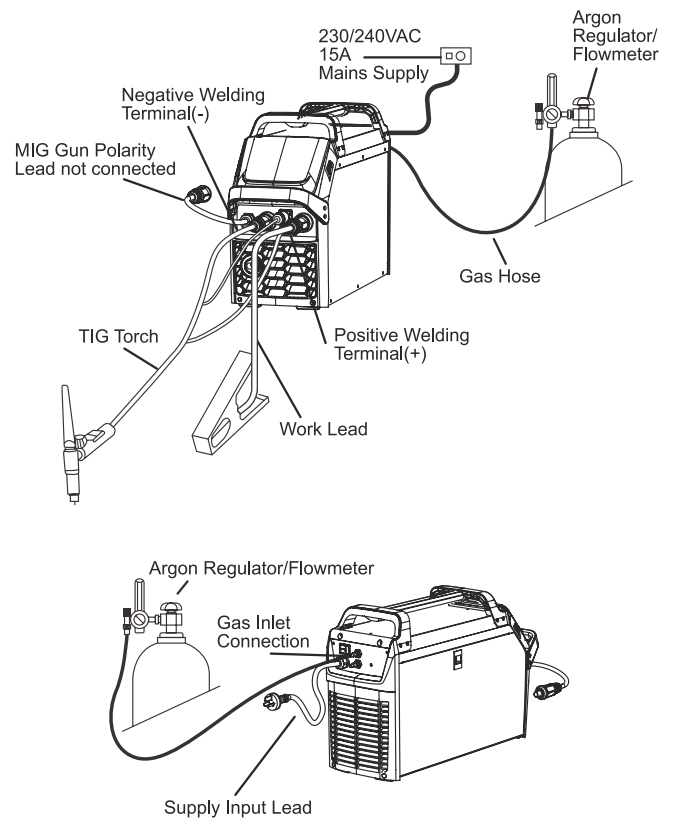

Figure 6-4: Setup For TIG (GTAW) Welding

## 6.07 TIG WELDING ISSUES - CAUSE & REMEDY

FAULT	CAUSE	REMEDY
Excessive bead build up or poor penetration or poor fusion at edges of weld.	Welding current is too low.	Increase weld current and/or faulty joint preparation.
Weld bead too wide and flat or undercut at edges of weld or excessive burn through.	Welding current is too high.	Decrease weld current.
Weld bead too small or insufficient penetration or ripples in bead are widely spaced apart.	Travel speed too fast.	Increase travel speed.
Weld bead too wide or excessive bead build up or excessive penetration in butt joint.	Travel speed too slow.	Increase travel speed.
Uneven leg length in fillet joint.	Wrong placement of filler rod.	Re-position filler rod.
Electrode melts or oxidises when an arc is struck.	<p>A. Torch lead connected to positive welding terminal.</p> <p>B. No shielding gas flowing to welding region.</p> <p>C. Torch is clogged with dust or dirt.</p> <p>D. Shielding gas hose is damaged.</p> <p>E. Shielding gas regulator turned off.</p> <p>F. The electrode is too small for the welding current.</p>	<p>A. Connect torch lead to negative welding terminal.</p> <p>B. Check the shielding gas lines for kinks or breaks and shielding gas cylinder contents.</p> <p>C. Clean torch.</p> <p>D. Replace shielding gas hose.</p> <p>E. Turn On Shielding Gas and adjust Shielding Gas flow rate for the welding job.</p> <p>F. Increase electrode diameter or reduce the welding current.</p>
Dirty weld pool	<p>A. Electrode contaminated by contact with work piece or filler rod material.</p> <p>B. Work piece surface has foreign material on it.</p> <p>C. Shielding gas contaminated with air.</p>	<p>A. Clean the electrode by grinding off the contaminates.</p> <p>B. Clean surface.</p> <p>C. Check shielding gas lines for cuts and loose fitting or change shielding gas cylinder.</p>
Poor weld finish	Inadequate shielding gas.	A. Increase shielding gas flow or check shielding gas line for shielding gas flow problems.

FAULT	CAUSE	REMEDY
Arc start is not smooth.	A. Tungsten electrode is too large for the welding current.	A. Select the right size tungsten electrode. Refer to Table 6-3 Cigweld Tungsten Electrode Selection Chart.
	B. The wrong electrode is being used for the welding job.	B. Select the right size tungsten electrode type. Refer to Table 6-3 Cigweld Tungsten Electrode Selection Chart.
	C. Shielding gas flow rate is too high.	C. Select the right shielding gas flow rate for the welding job.
	D. Incorrect shielding gas is being used.	D. Select the correct shielding gas.
	E. Poor work clamp connection to work piece.	E. Improve connection to work piece.
Arc flutters during TIG welding.	A. Tungsten electrode is too large for the welding current.	A. Select the right size tungsten electrode. Refer to Table 6-3 Cigweld Tungsten Electrode Selection Chart.

Table 6-5: TIG (GTAW) Welding Problems

# SECTION 7: STICK (MMA) WELDING

## 7.01 STICK (MMA) MODE SETUP



### 1. Menu Button

Press the Menu Button to display a drop down list of the available welding Mode Parameters. Rotate the Left Control Knob to scroll through the available options, press to confirm and move to the next parameter. Optionally, press the Menu Button to move to the next parameter without confirming a selection. After a short period, if no input is made to the Menu Button or Left Control Knob, the drop down list will disappear without confirming the highlighted option.

### 2. Mode Parameters

The Mode Parameters available depend on the MMA welding mode selected. MMA Manual welding mode is limited to only enabling pulse. Refer to Section 5.02 for the available MIG Mode Parameters.

### 3. Weld Parameters



The left side of the screen displays the available Weld Parameters. Rotate the Left Control Knob to highlight the desired parameter, then rotate the Right Control Knob to adjust the value.



The right side of the screen displays the live output welding voltage and the value of the highlighted Weld Parameter. Rotate the Right Control Knob to adjust the Weld Parameter value. When welding, the output current will be displayed instead, overwriting the Weld Parameter value.

Additionally, MMA Synergic mode will display a Plate Thickness value. This value depends on the Peak Current and Joint Type selected, and is to be used as a guide only.

4. VRD Indicator



Green VRD text will be displayed at the top of the screen when the Voltage Reduction Device is active. When inactive the text will disappear.

VRD activates when no arc is present and while the output terminals are live. VRD reduces the Open Circuit Voltage below 35V to reduce the risk of electric shock if the operator comes into contact with the welding terminals or electrodes.. When a welding arc is present, VRD deactivates as to not impede welding performance.

7.02 STICK (MMA) - MODE PARAMETERS

PARAMETER	OPTIONS AVAILABLE	DESCRIPTION
MMA Mode	MMA MAN.	<b>MMA Manual</b> This is the standard mode found on most MMA welders. In this mode the operator has complete control over the Weld Control parameters.
	MMA SYN.	<b>MMA Synergic</b> Utilizes pre-installed weld settings referred to as Synergic Lines. The operator simply selects the remaining Mode Parameters, and a recommended Welding current and Plate Thickness is set.
Pulse	On Off	When enabled the output signal is pulsed between the Peak Current and Base Current. Utilizing the pulse function can improved weld quality, offering better control over the welding process, especially when working with challenging materials or in demanding welding applications.
Electrode Material	CS-Low H E7018 CS-Rutile E6013 SS E316L/E308L	The Electrode Material parameter is used to set the Synergic Welding Current and Plate Thickness to ensure a reliable weld based on the material's properties.  <i>Only available in TIG Synergic mode.</i>
Electrode Diameter	1.6mm 2.0mm 2.5mm 3.2mm 4.0mm	The Electrode Diameter parameter is used to set the Synergic Welding Current and Plate Thickness to ensure an optimal weld. The available options are dependent on the Electrode Material selected.  <i>Only available in TIG Synergic mode.</i>

PARAMETER	OPTIONS AVAILABLE	DESCRIPTION
Joint Type	Fillet Weld	The Joint Type parameter is used to set the Synergic Welding Current and Plate Thickness to ensure a reliable weld.  <i>Only available in TIG Synergic mode.</i>
	Lap Weld	
	Butt Weld	
	Vertical Weld	
	Horizontal Weld	

Table 7-1: MMA (Stick)- Mode Parameters

## 7.03 STICK (MMA) - WELD PARAMETERS

PARAMETER	VALUE RANGE	DEFAULT VALUE	DESCRIPTION
Hot Start	0 – 10	0	The Hot Start improves the arc start characteristics by momentarily increasing the output current to a high level, preventing the electrode from sticking. Refer also Section 4.05.
Hot Start Time	0.0 – 2.0s	0.1s	Hot Start Time is the time in seconds that the Hot Start setting will run for. Refer also Section 4.05.
Welding Current	10A – Max Current	50A	Welding Current is the current output to the electrode. If pulse is enabled this is the higher current of the pulse cycle, generating more heat, allowing for better fusion and penetration into the base metal.
Base Current	10A – Peak Current	10A	Base Current is the lower current of the Pulse Cycle. It helps reduce heat buildup, minimizing the risk of distortion and burn-through.  <i>Only available when pulse is enabled</i>
Pulse Width	15 – 95%.	50%	Pulse Width is the amount of time the output current remains at the Peak Current level before returning to the Base Current level. This is measured as a percentage of the Pulse Frequency.  <i>Only available when pulse is enabled</i>
Pulse Frequency	0.5 – 300Hz	1Hz	Pulse Frequency is the number of times per second that the output current cycles between the Peak Current and Base Current. Higher frequencies result in more rapid cycling between the two current levels.  <i>Only available when pulse is enabled</i>

PARAMETER	VALUE RANGE	DEFAULT VALUE	DESCRIPTION
Arc Force	0 – 10	0	Arc Force provides an automatic boost to the Welding Current when the electrode gets too close to the work piece. This assists in stabilizing the arc, preventing the arc from cutting out and the electrode sticking.
Arc Length	-10 – 0	0	Arc Length adjusts the length of the welding arc, determining the width and size of the arc cone. As Arc Length decreases, the Arc Cone becomes narrower, the arc is more focused resulting in a smaller weld bead. Conversely, as Arc Length increases, the arc cone becomes wider resulting in a larger, flatter weld bead.

Table 7-2: MMA (Stick)- Weld Parameters

## 7.04 STICK WELDING BASICS

Metal arc welding electrodes consist of a core wire surrounded by a flux coating. This flux coating, applied to the core wire by an extrusion process, serves the following key functions:

- A. To provide a gaseous shield for the weld metal, preserving it from contamination by the atmosphere whilst in a molten state.
- B. To steady the arc by providing an arc stabilising bridge for the flow of the welding current.
- C. To provide deoxidisers for the removal of oxygen from the weld metal and weld pool.
- D. To provide a cleansing action on the work piece and a protective slag cover over the weld metal to prevent the formation of oxides while the metal is solidifying. The slag also helps to produce a bead of the desired contour.
- E. To introduce alloys into the weld deposits in special type electrodes.

### Stick Electrode Types

Arc Welding electrodes are classified into a number of groups depending on their applications. There are a great number of electrodes used for specialised industrial purposes which are not of particular interest for everyday general work. These include some low hydrogen types for high tensile steel, cellulose types for welding large diameter pipes, etc. The range of electrodes dealt with in this publication will cover the vast majority of applications likely to be encountered; are all easy to use and all will work on even the most basic of welding machines.

## CIGWELD ELECTRODE SELECTION CHART

DESCRIPTION	CLASS.	DIA.	PACK	PART NO	APPLICATION
<b>SATINCRAFT 13</b>	B E4313 A (AUS/NZ STD)	2.5mm	2.5kg Pack	612182	A high performance General Purpose (GP) welding electrode suitable for all positional welding, except vertical-down, for use on, mild and galvanised steel pipes, plates, angle iron, RHS, tubes and grid mesh.
		2.5mm	5kg Pack	611182	
		3.2mm	2.5kg Pack	612183	
		3.2mm	5kg Pack	611183	
	E6013 (AWS STD)	4mm	5kg Pack	611184	
<b>WELDSKILL GP GENERAL PURPOSE WELDING</b>	B E4313 A (AUS/NZ STD)	2.0mm	25 Rod Handypack	WEG0220	A user-friendly General Purpose (GP) electrode offering a quiet, smooth arc action with a 6013 classification (min. strength rating of 60,000PSi). Ideal for welding thin section mild, galvanised and rusty steels and weld joints with poor fit-up. Great for use on vertical down fillet welding applications. Weldskill GP produces smooth professional mitre fillet welds in all positions with very low spatter levels, it features positive re-strike (hot or cold) and a self-releasing slag.
		2.0mm	1.0kg Pack	WEG1020	
	2.0mm	2.5kg Pack	WEG2520		
	E6013 (AWS STD)	2.5mm	20 Rod Handypack	WEG0225	
		2.5mm	1.0kg Pack	WEG1025	
	2.5mm	2.5kg Pack	WEG2525		
	2.5mm	5.0kg Pack	WEG5025		
	3.2mm	15 Rod Handypack	WEG0232		
	3.2mm	1.0kg Pack	WEG1032		
	3.2mm	2.5kg Pack	WEG2532		
3.2mm	5.0kg Pack	WEG5032			
<b>WELDSKILL HS HIGHER STRENGTH</b>	B E4916 U A H10 (AUS/NZ STD)	2.5mm	1.0kg Pack	WEL1025	Higher Strength (HS) Hydrogen Controlled welding electrodes with a 7016 classification (min. strength rating of 70,000 PSi), well suited to welding steels under stress or with higher load bearing. The full covering slag is easy to control and remove.
		3.2mm	1.0kg Pack	WEL1032	
	E7016 H8 (AWS STD)				
<b>WELDSKILL WELDIT ALL DISSIMILAR STEEL WELDING</b>	B ES312-17 (AUS/NZ STD)	2.5mm	10 Rod Handypack	WEW0225	WELDIT ALL is a highly alloyed stainless steel electrode that is extremely resistant to cracking (min. strength of 110,000PSi) it provides smooth, stable running in all positions (except vertical down) especially on low current settings. WELDIT ALL is recommended for the repair and maintenance of all steels, particularly those of unknown composition. It is suitable for; Joining dissimilar steels, such as stainless steel to carbon steel, Repairing die or tool steels, as a protective overlay against corrosion and as an intermediate or buffer layer prior to hard surfacing. Not Recommended for Welding Cast Irons
		2.5mm	1.0kg Pack	WEW1025	
	3.2mm	10 Rod Handypack	WEW0232		
	E312-17 (AWS STD)	3.2mm	1.0kg Pack	WEW1032	

**CIGWELD ELECTRODE SELECTION CHART**

DESCRIPTION	CLASS.	DIA.	PACK	PART NO	APPLICATION
WELDSKILL HARDA HARDFACING	1855-A4 (AUS/NZ STD) --	3.2mm	1.0kg Pack	WEH1032	HARDA is designed for hard surfacing of steel components subjected to wet or dry hard particle abrasion and low to moderate impact loading. The air hardening (~55RHc), low alloy steel deposit of WELDSKILL HARDA remains crack free on most steels and is therefore recommended for hard surfacing components subject to flexing during service. Typical applications include the surfacing of agricultural points, shears and tynes, grader and dozer blades, conveyor screws and post hole augers etc.
WELDSKILL CAST2STEEL	--	2.5mm	10 Rod Handypack	WEC0225	CAST2STEEL is a Nickel-Iron electrode designed for higher strength repair and maintenance welding of SG, Austenitic, Meehanites and Grey cast irons. It produces a soft stable arc with minimal penetration and spatter. The ductile Nickel-Iron weld deposit is machinable with the higher strength required for welding S.G. irons. Cast2Steel is also used to weld Cast Iron to Mild and Low Alloy Steels.
CAST IRONS & CAST TO STEEL	ENiFe-CI (AWS STD)	2.5mm 3.2mm 3.2mm	1.0kg Pack 10 Rod Handypack 1.0kg Pack	WEC1025 WEC0232 WEC1032	

Table 7-3: Electrode selection chart

## 7.05 STICK WELDING

- A. Select Stick mode with the process selection control.
- B. Connect the Electrode Holder lead to the positive welding terminal (+). If in doubt, consult the electrode manufacturer. Welding current flows from the Power Source via Dinse type terminals. It is essential, however, that the male plug is inserted and turned securely to achieve a sound electrical connection.
- C. Connect the work lead to the negative welding terminal (-). If in doubt, consult the electrode manufacturer. Welding current flows from the power source via Dinse type terminals. It is essential, however, that the male plug is inserted and turned securely to achieve a sound electrical connection.



### WARNING

Before connecting the work clamp to the work and inserting the electrode in the electrode holder make sure the Mains power supply is switched off.



### CAUTION

Remove any packaging material prior to use. Do not block the air vents at the front or rear of the Welding Power Source.



### NOTE

Consult the electrode manufacturer's information for the correct polarity.

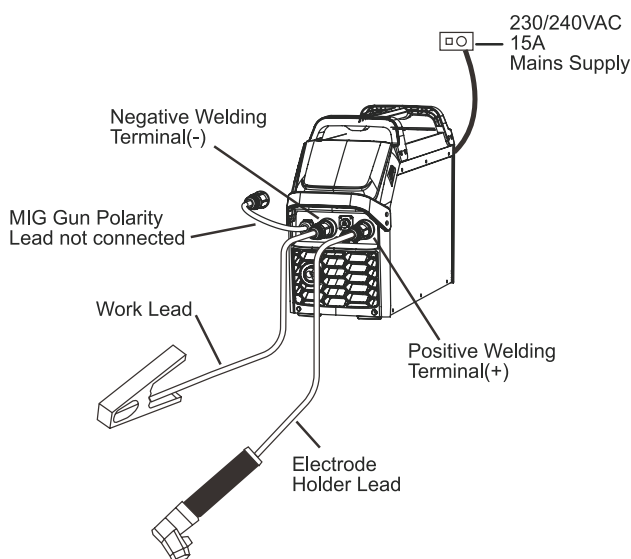

Figure 7-1: Setup For STICK (MMAW) Welding

### Storage of Stick Electrodes

Always store electrodes in a dry place and in their original containers.

### Stick Electrode Size

The electrode size is determined by the thickness of metals being joined and can also be governed by the type of welding machine available. Small welding machines will only provide sufficient current (amperage) to run the smaller size electrodes.

For most work, a 2.5mm electrode will be quite sufficient. A 2.5mm electrode will give just as strong a joint but may require a few more weld runs to be put down to fill the joint.

For thin sections, it is necessary to use smaller electrodes otherwise the arc may burn holes through the job. A little practice will soon establish the most suitable electrode for a given application.

### Electrode Polarity

Electrodes are connected to the Electrode Holder, and the Work Lead is connected to the work piece.

Consult the Electrode manufacturer's information for the correct polarity.

### STICK Welding Practice

Techniques used for arc welding are almost identical regardless of what types of metals are being joined.

Naturally enough, different types of electrodes would be used for different metals as described in the next section.

### STICK Welding Different Metals

#### A. High tensile and alloy steels

The two most prominent effects of welding these steels are the formation of a hardened zone in the weld area, and, if suitable precautions are not taken, the occurrence in this zone of under-bead cracks may result. Hardened zone and under-bead cracks in the weld area may be reduced by using the correct electrodes, preheating, using higher current settings, using larger electrode sizes, short runs for larger electrode deposits or tempering in a furnace.

#### B. Austenitic manganese steels

The effect on manganese steel of slow cooling from high temperatures is to embrittle it. For this reason it is absolutely essential to keep manganese steel cool during welding by quenching after each weld or skip welding to distribute the heat.

**C. Cast Iron**

Most types of cast iron, except white iron, are weldable. White iron, because of its extreme brittleness, generally cracks when attempts are made to weld it. Trouble may also be experienced when welding white-heart malleable, due to the porosity caused by gas held in this type of iron.

**D. Copper and alloys**

The most important factor is the high rate of heat conductivity of copper, making preheating of heavy sections necessary to give proper fusion of weld and base metal.

**Welding Position**

The electrodes dealt with in this publication can be used in most positions, i.e. they are suitable for welding in flat, horizontal, vertical and overhead positions. Numerous applications call for welds to be made in positions intermediate between these. Some of the common types of welds are shown in Figures 7-3 through 7-10.

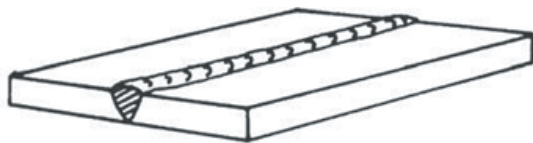

Figure 7-2: Flat position, down hand butt weld

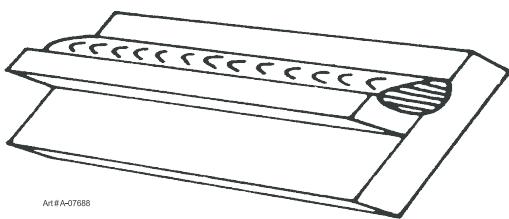

Figure 7-3: Flat position, gravity fillet weld

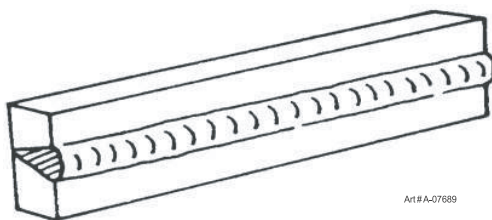
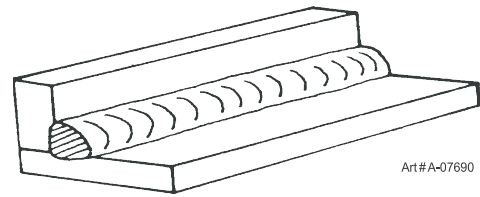
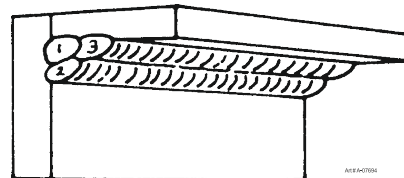

Figure 7-4: Horizontal position, butt weld



Art#A-07690

Figure 7-5: Flat position, down hand fillet weld



Art#A-07691

Figure 7-6: Overhead position fillet, weld

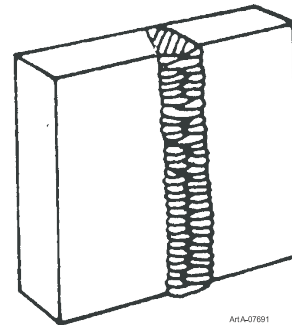

Art#A-07691

Figure 7-7: Vertical position, butt weld



Figure 7-8: Overhead position, butt weld

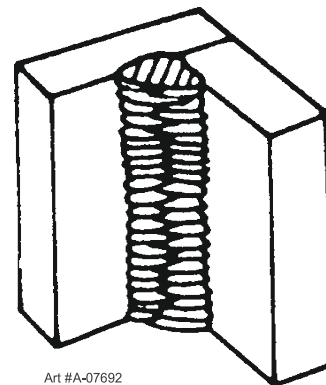

Art #A-07692

Figure 7-9: Vertical position, fillet weld

## 7.06 STICK WELDING ISSUES - CAUSE & REMEDY

DESCRIPTION	POSSIBLE CAUSE	REMEDY
1. Gas pockets or voids in weld metal (Porosity).	A. Electrodes are damp. B. Welding current is too high. C. Surface impurities such as oil, grease, paint, etc.	A. Dry electrodes before use. B. Reduce welding current. C. Clean joint before welding.
2. Crack occurring in weld metal soon after solidification commences.	A. Rigidity of joint. B. Insufficient throat thickness. C. Cooling rate is too high.	A. Redesign to relieve weld joint of severe stresses or use crack resistance electrodes. B. Travel slightly slower to allow greater build-up in throat. C. Preheat plate and cool slowly.
3. A gap is left by failure of the weld metal to fill the root of the weld.	A. Welding current is too low. B. Electrode too large for joint. C. Insufficient gap. D. Incorrect sequence.	A. Increase welding current. B. Use smaller diameter electrode. C. Allow wider gap. D. Use correct build-up sequence.

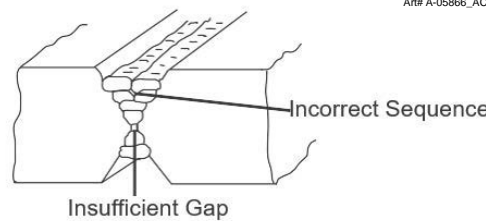

Figure 7-10: Example of Insufficient Gap or Incorrect Sequence

4. Portions of the weld run do not fuse to the surface of the metal or edge of the joint.	A. Small electrodes used on heavy cold plate.	A. Use larger electrodes and preheat the plate.
	B. Welding current is too low.	B. Increase welding current.
	C. Wrong electrode angle.	C. Adjust angle so the welding arc is directed more into the base metal.
	D. Travel speed of electrode is too high.	D. Reduce travel speed of electrode.
	E. Scale or dirt on joint surface.	E. Clean surface before welding.

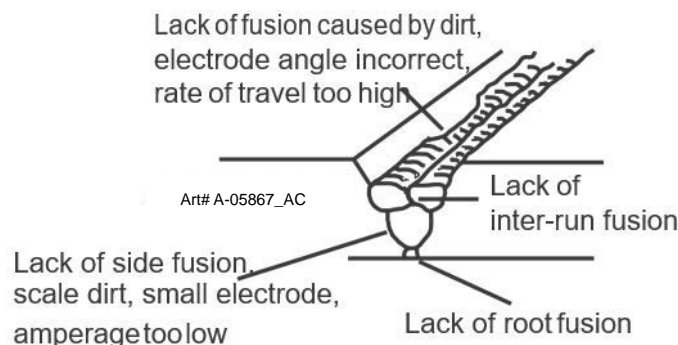
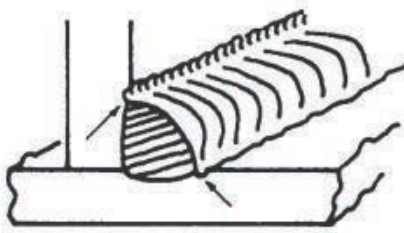

Figure 7-11: Example of Lack of Fusion

DESCRIPTION	POSSIBLE CAUSE	REMEDY
5. A groove has been formed in the base metal adjacent to the toe of a weld and has not been filled by the weld metal (undercut).	A. Welding current is too high. B. Welding current is too low. C. Angle of the electrode is incorrect. D. Joint preparation does not allow correct electrode angle. E. Electrode too large for joint. F. Insufficient deposit time at edge of weave.	A. Reduce welding current. B. Reduce the length of the welding arc. C. Electrode should not be inclined less than 45° to the vertical face. D. Allow more room in joint for manipulation of the electrode. E. Use smaller gauge electrode. F. Pause for a moment at edge of weave to allow weld metal build-up.



Art# A-07714

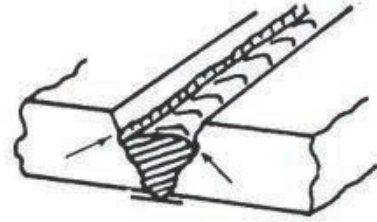
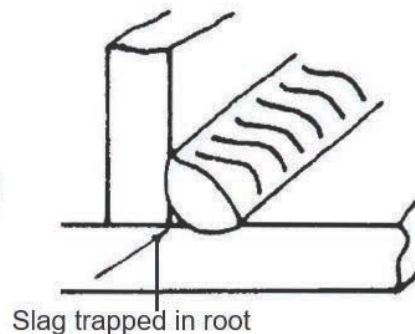
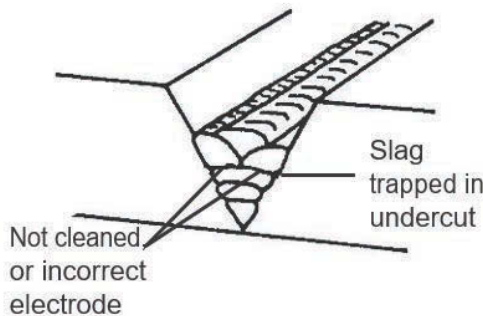

Figure 7-12: Examples of undercut

6. Non-metallic particles are trapped in the weld metal (slag inclusion.)	A. Non-metallic particles may be trapped in undercut from previous run. B. Joint preparation too restricted. C. Irregular deposits allow slag to be trapped. D. Lack of penetration with slag trapped beneath weld bead. E. Rust or mill scale is preventing full fusion. F. Wrong electrode for position in which welding is done.	A. If bad undercut is present, clean slag out and cover with a run from a smaller diameter electrode. B. Allow for adequate penetration and room for cleaning out the slag. C. If very bad, chip or grind out irregularities. D. Use smaller electrode with sufficient current to give adequate penetration. Use suitable tools to remove all slag from corners. E. Clean joint before welding. F. Use electrodes designed for position in which welding is done, otherwise proper control of slag is difficult.
---	--	---



Art# A-05866\_AC

Figure 7-13: Examples of Slag Inclusion

Table 7-4: Welding Issues - Cause & Remedy

# SECTION 8: ROUTINE SERVICE REQUIREMENTS AND POWER SOURCE PROBLEMS

## 8.01 A ROUTINE MAINTENANCE & INSPECTION



### **ELECTRICAL WARNING**

There are extremely dangerous voltage and power levels present inside this product. Do not attempt to open or repair unless you are a qualified electrical tradesperson. Disconnect the Welding Power Source from the Mains Supply Voltage before disassembling.

Welding equipment should be regularly checked by a qualified electrical tradesperson to ensure that:

- The main earth wire of the electrical installation is intact.
- Power point for the Welding Power Source is effectively earthed and of adequate current rating.
- Plugs and cord extension sockets are correctly wired.
- Flexible cord is of the 3-core tough rubber or plastic sheathed type of adequate rating, correctly connected and in good condition.
- Welding terminals are shrouded to prevent inadvertent contact or short circuit.
- The frame of the Welding Power Source is effectively earthed.
- Welding leads and electrode holder are in good condition.
- The Welding Power Source is clean internally, especially from metal filing, slag, and loose material. If any parts are damaged for any reason, replacement is recommended.

## 8.02 CLEANING THE WELDING POWER SOURCE

To clean the Welding Power Source, open the enclosure and use a vacuum cleaner to remove any accumulated dirt, metal filings, slag and loose material. Keep surfaces clean as accumulated foreign material may reduce the welders output welding current.



### CAUTION

Do not use compressed air to clean the Welding Power Source. Compressed air can force metal particles to lodge between live electrical parts and earthed metal parts within the Welding Power Source. This may result in arcing between these parts and their eventual failure.

## 8.03 CLEANING THE FEED ROLLS

Clean the grooves in the feed rolls frequently. This can be done by using a small wire brush. Also wipe off or clean the grooves on the upper feed roll. After cleaning, tighten the feed roll retaining knobs.

## 8.04 BASIC TROUBLESHOOTING



### ELECTRICAL WARNING

There are extremely dangerous voltage and power levels present inside this product. Do not attempt to open or repair unless you are a qualified electrical tradesperson and you have had training in power measurements and troubleshooting techniques.

If major complex subassemblies are faulty, then the Welding Power Source must be returned to an Accredited CIGWELD Service Agent for repair.

The basic level of troubleshooting is that which can be performed without special equipment or knowledge.

Refer to Sections 5.20, 5.21, 6.07 and 7.06 for common welding issues and remedies.

## 8.05 BLUEVENOM SiC ERROR CODES



Figure 8.1: Warning Screen Example

ERROR CODE	CAUSE	REMEDY
E01	Over-heating	Duty cycle of the Power Source has been exceeded. Leave the power source switched ON with the fan running and allow it to cool.
E02		Check front and rear Panel Air Louvres are clean and not blocked by any dirt or obstacles. If damaged, they should be replaced by an accredited CIGWELD Service Provider.
E03		Check that the fan is running normally during welding. If the fan is not running during welding it may be faulty and need replacing. Contact an accredited CIGWELD Service Provider. Note this unit has Fan on Demand fitted. Refer to Section 4 for further details.
E04		
E09		
E10	Phase loss	Input Power Supply is outside the parameters of the machine. Contact a Qualified Electrician to check the input Power Supply.
E34	Output terminal short circuit	The positive and negative output terminals have short circuited while in Stick welding mode. Turn off the welder and wait for it to power down. Move the electrodes or remove any material causing the short circuit.
E40	Internal communication error	A communication error occurred between the LCD Panel and the Control Board. Turn off the machine and wait at least 15 seconds before powering on. If the issue persists after powering on, the LCD touchscreen may be faulty and need replacing. Contact an accredited CIGWELD Service Provider.

Tabel 8-1: Error Codes

# SECTION 9: MIG GUN / TIG TORCH FRONT END CONSUMABLES

## 9.01 MIG GUN CONSUMABLES

### BINZEL® COMPATIBLE 24 SERIES

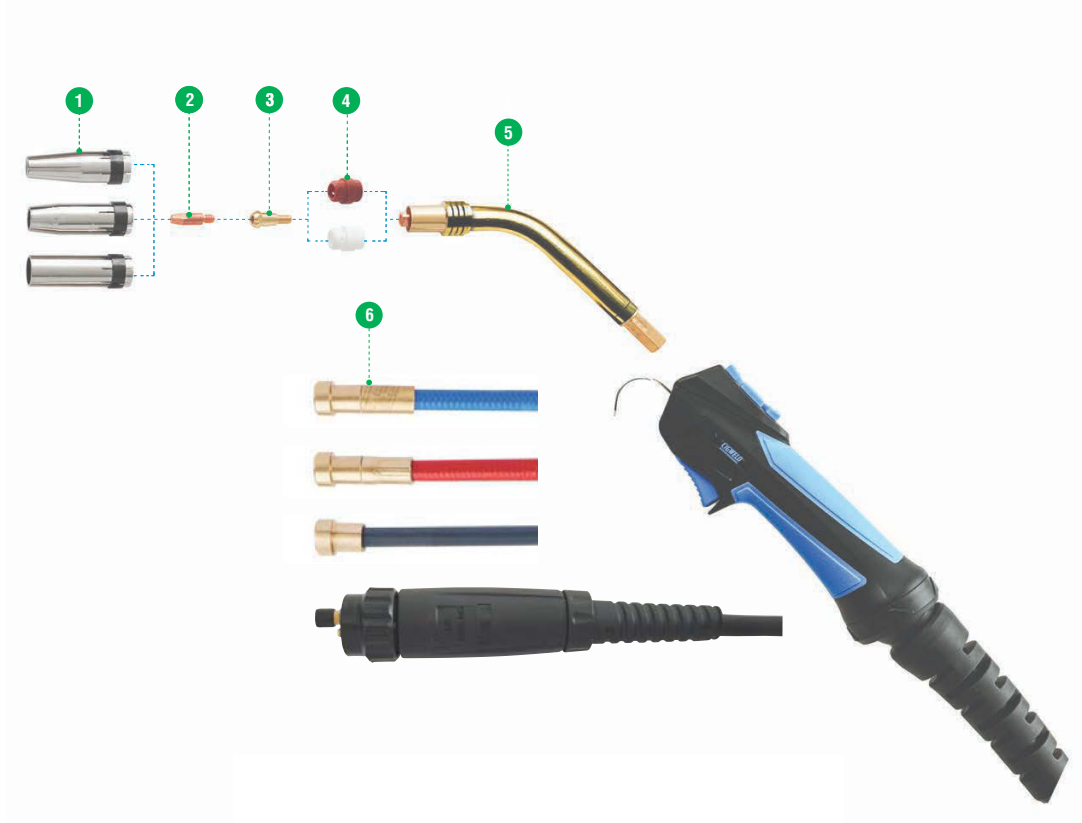

Figure 9-1: MIG GUN Consumable Parts

**MIG GUN BZ24 EURO 3M CONSUMABLE PARTS**

ITEM	PART NUMBER	DESCRIPTION
1	BZN2410	Nozzle Tapered 10mm
	BZN2413	Nozzle Conical 13mm
	BZN2417	Nozzle Cylindrical 17mm
2	BZT6806	Contact Tip 0.6mm M6
	BZT6808	Contact Tip 0.8mm M6
	BZT6809	Contact Tip 0.9mm M6
	BZT6810	Contact Tip 1.0mm M6(Suitable for 0.9mm AL Wires)
	BZT6812	Contact Tip 1.2mm M6 (Suitable for 1.0mm AL Wires)
	BZT6814	Contact Tip 1.4mm M6 (Suitable for 1.2mm AL Wires)
	BZT6816	Contact Tip 1.6mm M6
3	BZH24M6	Tip Holder M6
4	BZD24S	Diffuser Silicone
	BZD24	Diffuser Standard
5	W4023009	Gun Neck
6	CML5K0609	Multi Liner Kit Steel 0.6-0.9mm, 5.1m
	CML5K0912	Multi Liner Kit Steel 0.9-1.2mm, 5.1m
	CML5K1216	MultiLiner Kit Steel 1.2-1.6mm, 5.1m
	CML5K0916A	Multi Liner Kit Aluminium 0.9-1.6mm, 4.5m
	CML8K0916A	Multi Liner Kit Aluminium 0.9-1.6mm, 8.5m
	CMLCBZ	Multi Liner Collet suit Binzel

Table 9-1: BZ24 Consumables

**BINZEL® COMPATIBLE 36 SERIES**

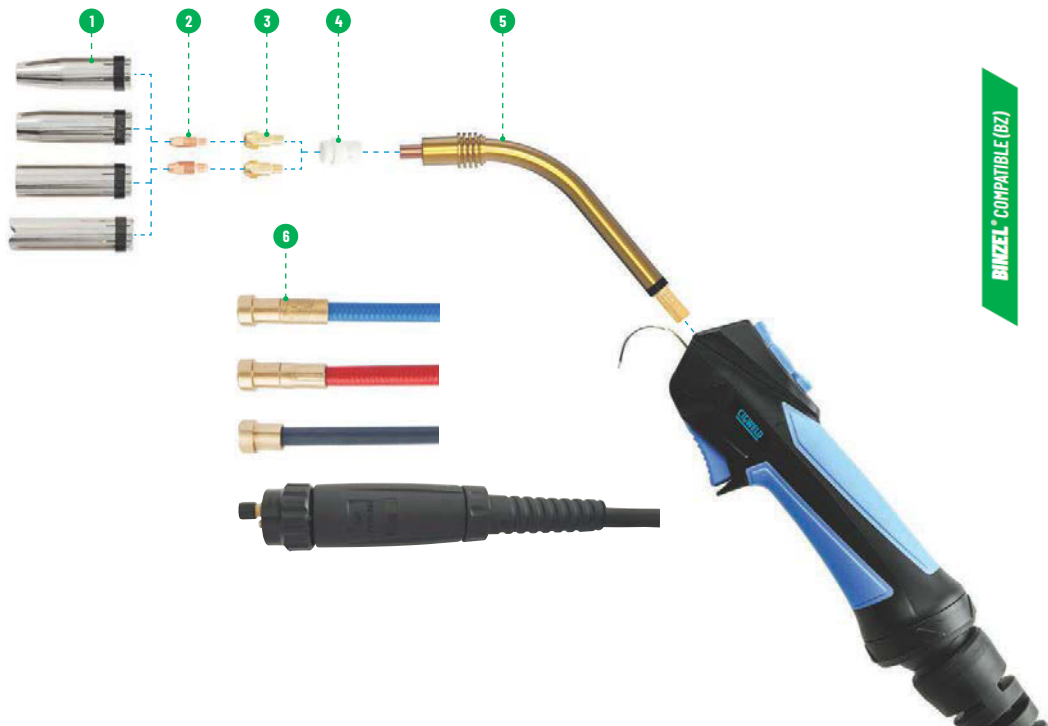

Figure 9-2: MIG Gun BZ36 Consumables Parts

**MIG GUN BZ36 EURO CONSUMABLE PARTS**

ITEM	PART NUMBER	DESCRIPTION
1	BZN3612	Nozzle Tapered 12mm
	BZN3616	Nozzle Conical 16mm
	BZN3620	Nozzle Cylindrical 20mm
	BZN3620S	Nozzle Spot Weld 20mm
2	BZT6806	Contact Tip 0.6mm M6
	BZT6808	Contact Tip 0.8mm M6
	BZT6809	Contact Tip 0.9mm M6
	BZT6810	Contact Tip 1.0mm M6 (Suitable for 0.9mm AL Wires)
	BZT6812	Contact Tip 1.2mm M6 (Suitable for 1.0mm AL Wires)
	BZT6814	Contact Tip 1.4mm M6 (Suitable for 1.2mm AL Wires)
	BZT6816	Contact Tip 1.6mm M6
	BZT61008	Contact Tip 0.8mm M8
	BZT61009	Contact Tip 0.9mm M8
	BZT61010	Contact Tip 1.0mm M8 (Suitable for 0.9mm AL Wires)
	BZT61012	Contact Tip 1.2mm M8 (Suitable for 1.0mm AL Wires)
	BZT61014	Contact Tip 1.4mm M8 (Suitable for 1.2mm AL Wires)
	BZT61016	Contact Tip 1.6mm M8
	BZT61018	Contact Tip 1.8mm M8
	BZT61020	Contact Tip 2.0mm M8
	BZT61024	Contact Tip 2.4mm M8
3	BZH36M6	Tip Holder M6, Pack of 2
	BZH36M8	Tip Holder M8, Pack of 2
4	BZD36	Diffuser Standard
5	W4023010	Gun Neck
6	CML5K0609	Multi Liner Kit Steel 0.6-0.9mm, 5.1m
	CML5K0912	Multi Liner Kit Steel 0.9-1.2mm, 5.1m
	CML5K1216	MultiLiner Kit Steel 1.2-1.6mm, 5.1m
	CML5K0916A	Multi Liner Kit Aluminium 0.9-1.6mm, 4.5m
	CML8K0916A	Multi Liner Kit Aluminium 0.9-1.6mm, 8.5m,
	CMLCBZ	Multi Liner Collet suit Binzel

Table 9-2: BZ36 Consumables

9.02 TIG TORCH CONSUMABLES

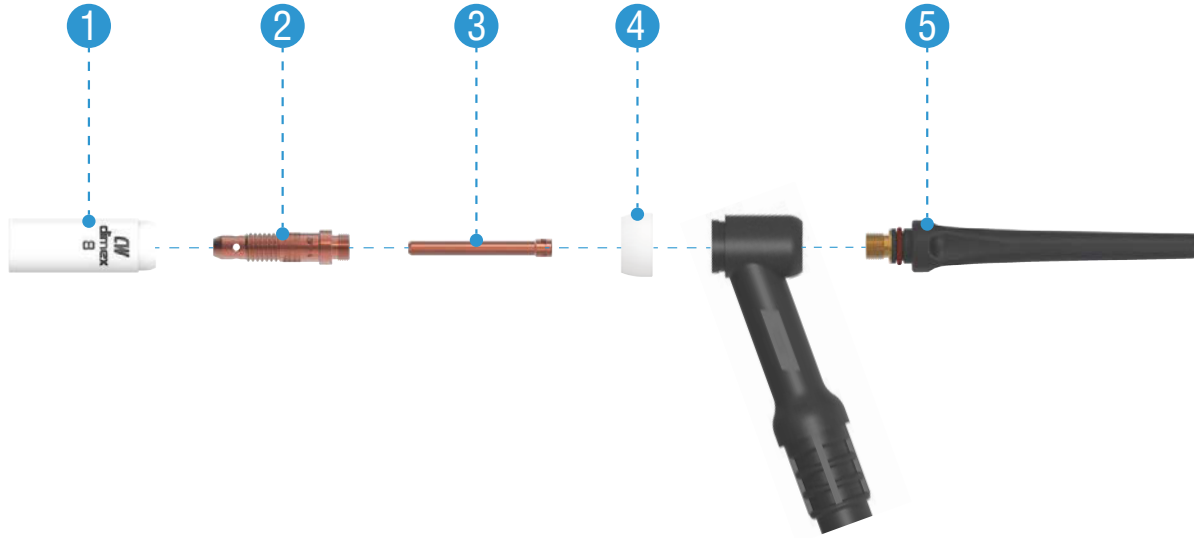

Figure 9-3:TIG Standard Consumables Parts

17/18/26 TIG TORCH CONSUMABLES - STANDARD

ITEM	PART NUMBER	DESCRIPTION
1	CW10N50	Ceramic Cup 6mm #4
	CW10N49	Ceramic Cup 8mm #5
	CW10N48	Ceramic Cup 10mm #6
	CW10N47	Ceramic Cup 11mm #7
	CW10N46	Ceramic Cup 13mm #8
	CW10N45	Ceramic Cup 16mm #10
	CW10N44	Ceramic Cup 19mm #12
	2	CW10N31
CW10N32		Collet Body - Standard 2.4mm
CW10N28		Collet Body - Standard 3.2mm
3	CW10N23	Collet - Standard 1.6mm
	CW10N24	Collet - Standard 1.6mm
	CW10N25	Collet - Standard 1.6mm
4	CW18CG	Insulator
5	CW57Y02	Back Cap Long
	CW57Y05	Back Cap Medium
	CW57Y04	Back Cap Short

Table 9-3: TIG Torch Consumables - Standard

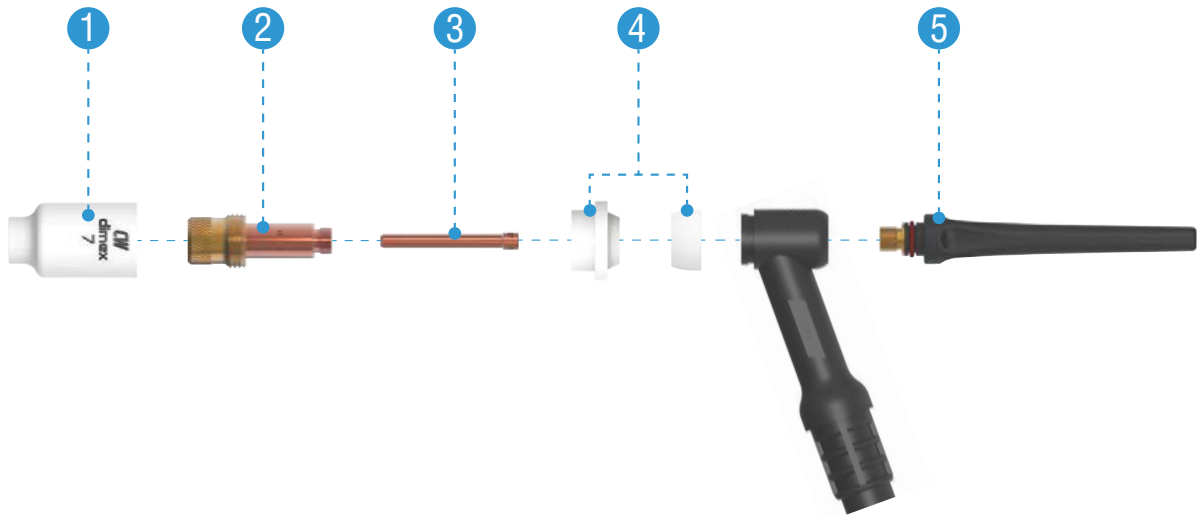

Figure 9-4:TIG Gas Lens Consumables Parts

**17/18/26 TIG TORCH CONSUMABLES - GAS LENS**

ITEM	PART NUMBER	DESCRIPTION
1	CW54N18	Ceramic Cup - Gas Lens 6mm #4
	CW54N17	Ceramic Cup - Gas Lens 8mm #5
	CW54N16	Ceramic Cup - Gas Lens 10mm #6
	CW54N15	Ceramic Cup - Gas Lens 11mm #7
	CW54N14	Ceramic Cup - Gas Lens 13mm #8
	CW54N19	Ceramic Cup - Gas Lens 17mm #11
	2	CW45V25
CW45V26		Collet Body - Gas Lens 2.4mm
CW45V27		Collet Body - Gas Lens 3.2mm
3	CW10N23	Collet - Standard 1.6mm
	CW10N24	Collet - Standard 2.4mm
	CW10N25	Collet - Standard 3.2mm
4	CW54N01	Insulator - Gas Lens (Use with CW18CG)
	CW18CG	Insulator
5	CW57Y02	Back Cap Long
	CW57Y05	Back Cap Medium
	CW57Y04	Back Cap Short

Table 9-4: TIG Torch Consumables - Gas Lens

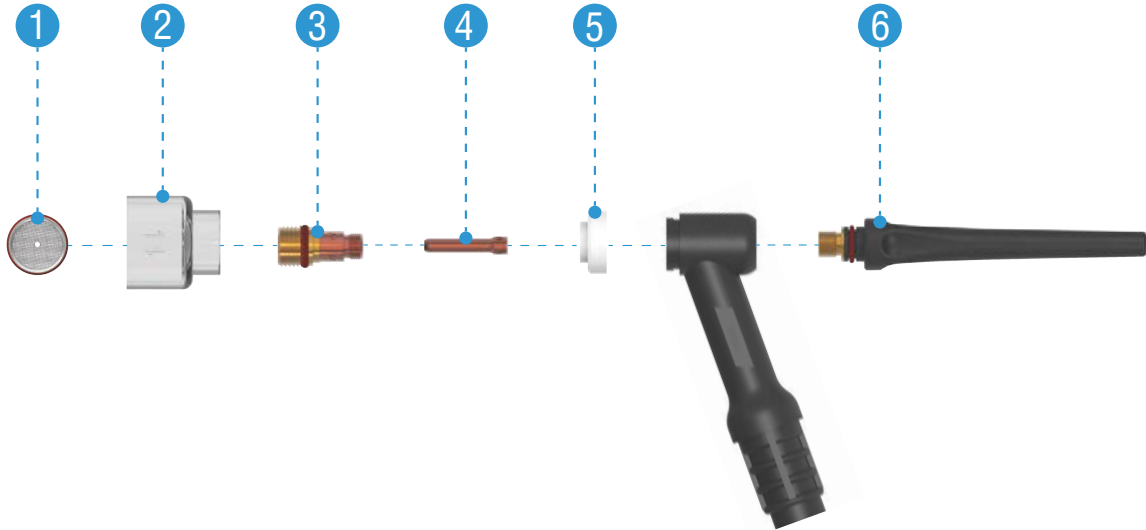

Figure 9-5:TIG Quartz Consumables Parts

**17/18/26 TIG TORCH CONSUMABLES - QUARTZ**

ITEM	PART NUMBER	DESCRIPTION
1	CW53NQ12-16	Screen Pack 1.6MM #12
	CW53NQ14-16	Screen Pack 1.6MM #14
	CW53NQ16-16	Screen Pack 1.6MM #16
	CW53NQ24-16	Screen Pack 1.6MM #24
	CW53NQ12-24	Screen Pack 2.4MM #12
	CW53NQ14-24	Screen Pack 2.4MM #14
	CW53NQ16-24	Screen Pack 2.4MM #16
	CW53NQ24-24	Screen Pack 2.4MM #24
	CW53NQ12-32	Screen Pack 3.2MM #12
	CW53NQ14-32	Screen Pack 3.2MM #14
	CW53NQ16-32	Screen Pack 3.2MM #16
	CW53NQ24-32	Screen Pack 3.2MM #24
	2	CW53NQCEN-12
CW53NQCEN-14		Quartz Champagne Cup 24mm #14
CW53NQCEN-16		Quartz Champagne Cup 27mm #16
3	CW53NQCEN-24	Quartz Champagne Cup 40mm #24
	CW4GL116NQ	Collet Body - Gas Lens, Quartz 1.6mm
	CW4GL332NQ	Collet Body - Gas Lens, Quartz 2.4mm
4	CW4GL418NQ	Collet Body - Gas Lens, Quartz 3.2mm
	CW10N23S	Collet - Stubby 1.6mm
	CW10N24S	Collet - Stubby 2.4mm
5	CW10N25S	Collet - Stubby 3.2mm
	CW18CG20GS	Insulator - Stubby
	6	CW57Y02
CW57Y05		Back Cap Medium
CW57Y04		Back Cap Short

Table 9-5: TIG Torch Consumables - Quartz

**BONUS!**

Using this setup of insulator, stubby collet and gas lens collet body, you can also fit 9/20 gas lens nozzles onto a 17/18/26 series Torch!

# SECTION 10: WARRANTY

## **CIGWELD**

AN ESAB BRAND

### **LIMITED WARRANTY TERMS**

LIMITED WARRANTY: CIGWELD Pty Ltd, An ESAB Brand, hereafter, “CIGWELD” warrants to customers of its Authorised distributors hereafter “Purchaser” that its products will be free of defects in workmanship or material. Should any failure to conform to this warranty appear within the time period applicable to the CIGWELD products as stated below, CIGWELD shall, upon notification thereof and substantiation that the product has been stored, installed, operated, and maintained in accordance with CIGWELD’s specifications, instructions, recommendations and recognized standard industry practice, and not subject to misuse, repair, neglect, alteration, or accident, correct such defects by suitable repair or replacement, at CIGWELD’s sole option, of any components or parts of the product determined by CIGWELD to be defective.

CIGWELD MAKES NO OTHER WARRANTY, EXPRESS OR IMPLIED. THIS WARRANTY IS EXCLUSIVE AND IN LIEU OF ALL OTHERS, INCLUDING, BUT NOT LIMITED TO ANY WARRANTY OF MERCHANTABILITY OR FITNESS FOR ANY PARTICULAR PURPOSE.

LIMITATION OF LIABILITY: CIGWELD SHALL NOT UNDER ANY CIRCUMSTANCES BE LIABLE FOR SPECIAL, INDIRECT OR CONSEQUENTIAL DAMAGES, SUCH AS, BUT NOT LIMITED TO, LOST PROFITS AND BUSINESS INTERRUPTION.

The remedies of the Purchaser set forth herein are exclusive and the liability of CIGWELD with respect to any contract, or anything done in connection therewith such as the performance or breach thereof, or from the manufacture, sale, delivery, resale, or use of any goods covered by or furnished by CIGWELD whether arising out of contract, negligence, strict tort, or under any warranty, or otherwise, shall not, except as expressly provided herein, exceed the price of the goods upon which such liability is based. No employee, agent, or representative of CIGWELD is Authorised to change this warranty in any way or grant any other warranty.

**PURCHASER’S RIGHTS UNDER THIS WARRANTY ARE VOID IF REPLACEMENT PARTS OR ACCESSORIES ARE USED WHICH IN CIGWELD’S SOLE JUDGEMENT MAY IMPAIR THE SAFETY OR PERFORMANCE OF ANY CIGWELD PRODUCT. PURCHASER’S RIGHTS UNDER THIS WARRANTY ARE VOID IF THE PRODUCT IS SOLD TO PURCHASER BY NON-Authorised PERSONS.**

The warranty is effective for the time stated below beginning on the date that the Authorised distributor delivers the products to the Purchaser. Not withstanding the foregoing, in no event shall the warranty period extend more than the time stated plus one year from the date CIGWELD delivered the product to the Authorised distributor.

Any claim under this warranty must be made within the warranty period which commences on the date of purchase of the product. To make a claim under the warranty, take the product (with proof of purchase from a CIGWELD Accredited Seller) to the store where you purchased the product or contact CIGWELD Customer Care 1300 654 674 for advice on your nearest Service Provider. CIGWELD reserves the right to request documented evidence of date of purchase. CIGWELD or our Accredited Distributor must be notified in writing of its claim within seven (7) days of becoming aware of the basis thereof, and at its own expense returning the goods which are the subject of the claim to CIGWELD or nominated Accredited Distributor/Accredited Service Provider

This warranty is given.

CIGWELD Pty Ltd A.B.N. 56007226815

71 Gower Street, Preston Victoria, Australia, 3072

Phone: 1300 654 674

Email: support@cigweld.com

Website: cigweld.com.au

This warranty is provided in addition to other rights and remedies you have under law: Our goods come with guarantees which cannot be excluded under the Australian Consumer Law. You are entitled to replacement or refund for a major failure and to compensation for other reasonably foreseeable loss or damage. You are also entitled to have the goods repaired or replaced if the goods fail to be of acceptable quality and the failure does not amount to a major failure.

Please note that the information detailed in this statement supersedes any prior published data produced by CIGWELD.

## WARRANTY SCHEDULE - BLUEVENOM SiC INVERTER

WARRANTY	WARRANTY PERIOD (PARTS AND LABOUR)
BlueVenom Sic Power Source	5 Years
ACCESSORIES	WARRANTY PERIOD
MIG Gun , TIG Torch, electrode holder lead and work lead	3 Months
MIG/TIG Gun consumable items	NIL
Gas Regulator/Flowmeter (excluding seat assembly, pressure gauges, elastomer seals and "O" rings	1 Year
Regulator seat assemblies and pressure gauges	6 Months
Elastomer seals and "O" rings used in the equipment	3 Months

## CIGWELD LIMITED WARRANTY DOES NOT APPLY TO;

- Obsolete goods sold at auction, second-hand goods and prototype goods.
- Consumable Parts for MIG, Plasma welding, Plasma cutting and Oxy fuel torches, O-rings, fuses, filters or other parts that fail due to normal wear.

### Notes:

- \* No employee, agent, or representative of CIGWELD is Authorised to change this warranty in any way or grant any other warranty, and CIGWELD shall not be bound by any such attempt. Correction of non-conformities, in the manner and time provided herein, constitutes fulfilment of CIGWELD's obligations to purchaser with respect to the product.
- \* This warranty is void, and seller bears no liability hereunder, if purchaser used replacement parts or accessories which, in CIGWELD's sole judgment, impaired the safety or performance of any CIGWELD product and if the unit is altered or serviced by an unauthorised CIGWELD Service Provider. Purchaser's rights under this warranty are void if the product is sold to purchaser by unAuthorised persons.





# ***CIGWELD***

AN **ESAB** BRAND

     | [CIGWELD.COM.AU](https://www.cigweld.com.au)