

# CIGWELD

AN ESAB BRAND

# COMET FLASHBACK ARRESTORS

## REGULATOR AND TORCH MOUNT



### TORCH MOUNT

  
100% FACTORY  
TESTED

  
2 POINT  
SAFETY SYSTEM

  
AUSTRALIAN  
STANDARDS

### REGULATOR MOUNT

  
100% FACTORY  
TESTED

  
3 POINT  
SAFETY SYSTEM

  
AUSTRALIAN  
STANDARDS

OXYGEN

FUEL



# COMET FLASHBACK ARRESTORS

The COMET range of Flashback Arrestors provide the perfect option for those looking to safeguard against flashbacks, backfires and sustained backfires, in a situation where extremely high gas flows are not required.

A flashback occurs when mixed gases within a cutting and welding blowpipe system ignite and burn back through the system against the flow of gas. The consequences of a flashback range from sooting of the hose, to serious equipment fires and possible explosion. The flashback can travel at supersonic speeds - faster than the operator can turn off the cylinder! So, if you hear a loud "pop" or "bang" then flashback has already occurred. Flashback arrestors when used & fitted correctly virtually eliminate the possibility of a flashback causing harmful damage.

Provides protection against flashbacks, backfires and sustained backfires

- NV** Non-Return Valve prevents reverse flow of gases
- FA** Stainless Steel Flame Arrestor extinguishes any returning flame
- TV** Gas flow will be shut-off if arrestor becomes overheated
- DF** Dust Filter protects the gas non-return valve against contamination

AS 4603; ISO 5175-1; \*UL 1357 Compliant



## REGULATOR MOUNTED FLASHBACK ARRESTOR

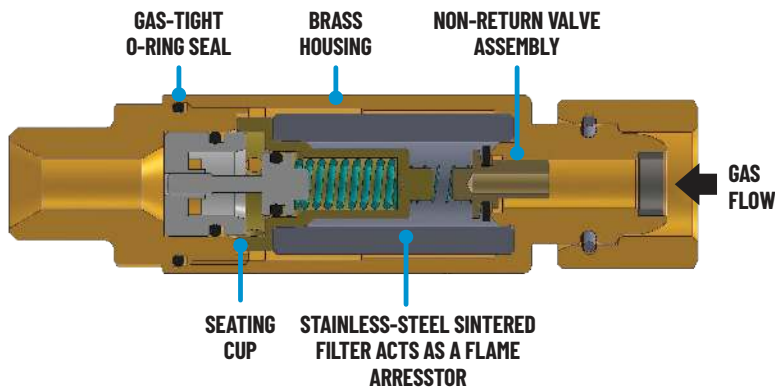

## TORCH MOUNTED FLASHBACK ARRESTOR

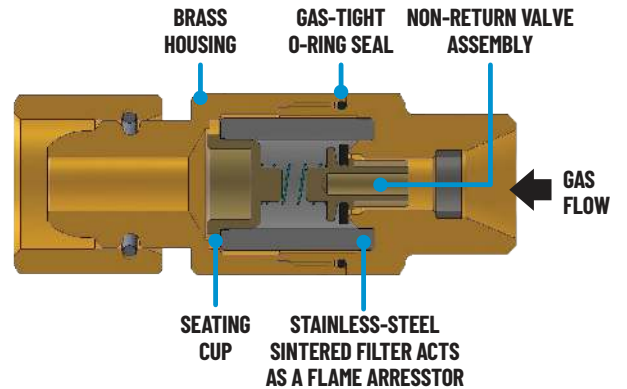

## MAXIMUM WORKING PRESSURE

GAS	MAXIMUM PRESSURE*
Oxygen	2500 kPa (25 Bar)
Acetylene	150 kPa (1.5 Bar)
Propane (LP)	500 kPa (5 Bar)
Methane	500 kPa (5 Bar)
Hydrogen	350 kPa (3.5 Bar)

## FEATURES

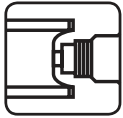

### FEATURES FLAME ARRESTOR AND NON-RETURN VALVE

Prevents chance of injury resulting from flashback, backfire and sustained backfire.



### REGULATOR MOUNTED SET

Allows for quick identification as to whether the unit is designed for Oxygen or Fuel use.



### TORCH MOUNTED SET

Allows for quick identification as to whether the unit is designed for Oxygen or Fuel use.



**DATE  
STAMP**  
01/23/4567

### DATE OF MANUFACTURE STAMPED ON BODY

Allows for quick identification as to when the unit should be replaced.



### COMPLIANCE

AS 4603 compliant, Provides the highest level of safety and performance. Ensures product is suitable for contracts requiring Australian Standards compliant product.



### \*UL LISTED

These FBA's are certified by UL 1357 to the following max working pressures: Acet: 15psi | Oxygen: 145psi | MPS Gas: 22psi | LP-Gas, Hydrogen, Natural Gas, Methane: 50psi



### ISO

Complies to ISO 5175 Gas welding equipment - Safety devices - Part 1: Devices incorporating a flame (flashback) arrester.

## COMET GAS FLOW CHARACTERISTICS

### Models: 208516 OXY | 208517 FUEL

$P_v$  = Opening pressure

$\Delta P$  = Inlet pressure - Outlet pressure

$\Delta P = P_v$     $\Delta P = 0.6\text{bar}$     $\Delta P = 0.3\text{bar}$

GAS	CONVERSION FACTOR
Air	1
Oxygen	0.95
Acetylene	1.05
LPG	0.8

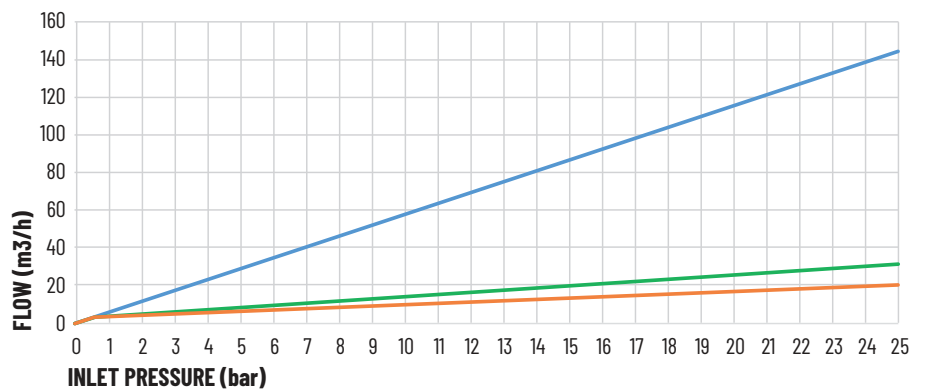

### Models: 208519 OXY | 208520 FUEL

$P_v$  = Opening pressure

$\Delta P$  = Inlet pressure - Outlet pressure

$\Delta P = P_v$     $\Delta P = 0.6\text{bar}$     $\Delta P = 0.3\text{bar}$

GAS	CONVERSION FACTOR
Air	1
Oxygen	0.95
Acetylene	1.05
LPG	0.8

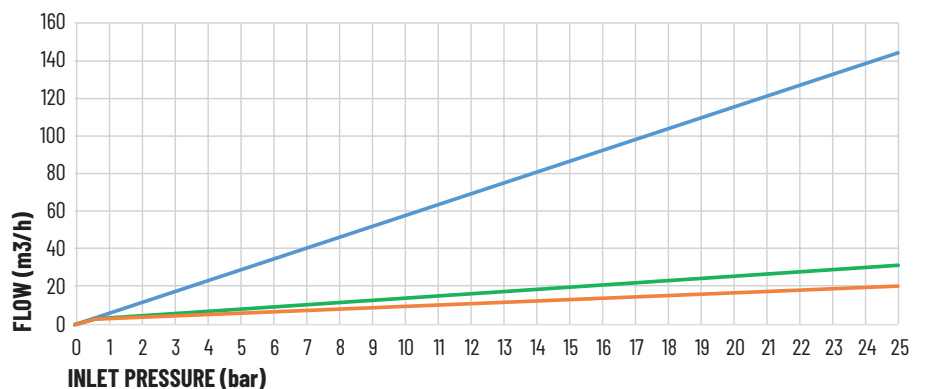

### Models: 208514 OXY | 208515 FUEL

$P_v$  = Opening pressure

$\Delta P$  = Inlet pressure - Outlet pressure

$\Delta P = P_v$     $\Delta P = 0.6\text{bar}$     $\Delta P = 0.3\text{bar}$

GAS	CONVERSION FACTOR
Air	1
Oxygen	0.95
Acetylene	1.05
LPG	0.8

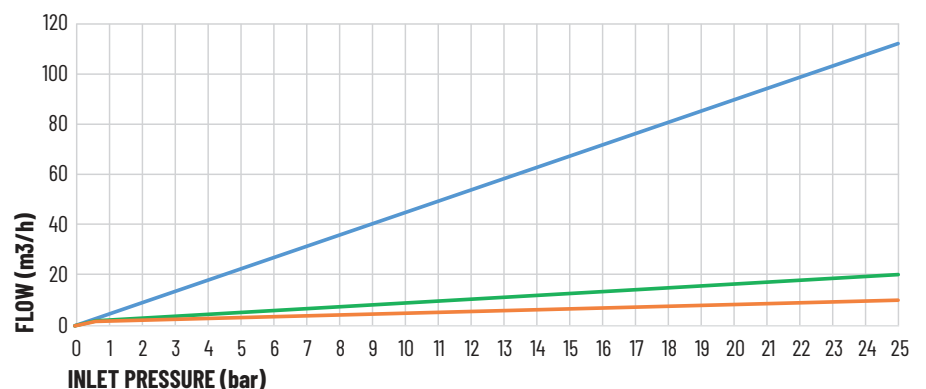

# CIGWELD

AN ESAB BRAND

# COMET FLASHBACK ARRESTORS

## REGULATOR AND TORCH MOUNT

These COMET™ FBA's are designed to prevent flashbacks or reverse flow of gas in oxy/fuel systems.



SCAN CODE FOR FULL PRODUCT DETAILS

### TORCH MOUNT



P/N: 208515

P/N: 208512

P/N: 208514

### REGULATOR MOUNT



P/N: 208517

P/N: 208513

P/N: 208516

### TORCH MOUNT: MID-FLOW



P/N: 208520

P/N: 208518

P/N: 208519

### ORDERING INFORMATION

TORCH MOUNT SET	OXYGEN	FA NV	208512
	FUEL	FA NV	208515
TORCH MOUNT	OXYGEN	FA NV	208514
TORCH MOUNT	FUEL	FA NV	208513

REGULATOR MOUNT SET	OXYGEN	FA NV TV	208513
	FUEL	FA NV TV	208516
REGULATOR MOUNT	OXYGEN	FA NV TV	208516
REGULATOR MOUNT	FUEL	FA NV TV	208517

TORCH MOUNT SET: MID-FLOW	OXYGEN	FA NV	208518
	FUEL	FA NV	208519
TORCH MOUNT: MID-FLOW	OXYGEN	FA NV	208519
TORCH MOUNT: MID-FLOW	FUEL	FA NV	208520



CIGWELD Pty Ltd An ESAB Brand 71 Gower Street, Preston VIC 3072 Australia  
 CUSTOMER CARE: Tel: 1300 654 674 | Intl Tel: +61 9474 7400  
 Email: enquiries@cigweld.com.au

[CIGWELD.COM.AU](http://CIGWELD.COM.AU)

In the interest of continuous improvements, CIGWELD Pty Ltd ABN 56 007 226 815 (An ESAB Brand) reserves the right to change specifications or design on any of its products without prior notice.